

## Carbon Steel

### ALPHA-NUMERIC LISTING

ACB/ACBX . . . . .12	W16 . . . . .32	W48 . . . . .20	W168 . . . . .33
<b>*ADOS/ADOSX . . . . .13</b>	W17 . . . . .32	W49 . . . . .20	W169 . . . . .34
<b>*AFA/AFAC . . . . .16</b>	W18 . . . . .32	W51 . . . . .27	W170 . . . . .33
<b>*AOP/AOPX . . . . .15</b>	W19 . . . . .32	W53 . . . . .9	W172 . . . . .34
AS/ASX . . . . .14	W22 . . . . .31	W58 . . . . .25	W176 . . . . .34
CP/CPX . . . . .12	W23 . . . . .28	W59 . . . . .24	W177 . . . . .34
F-FO . . . . .9	W24 . . . . .28	W60 . . . . .24	W180 . . . . .33
FOP/FP . . . . .8	W25 . . . . .28	W61 . . . . .24	W182 . . . . .35
FOPX/FPX . . . . .8	W26 . . . . .29	W62 . . . . .25	W184 . . . . .33
P-BWSF/P-BWSFN . . . . .10	W27 . . . . .28	W63 . . . . .25	W185 . . . . .33
P-BWSFX/P-BWSFXN . . . . .11	W28 . . . . .29	W65 . . . . .36	W186 . . . . .35
P-WSF . . . . .9	W29 . . . . .29	W66 . . . . .36	W187 . . . . .35
<b>*PTX . . . . .6</b>	W30 . . . . .29	W69 . . . . .30	W188 . . . . .33
S-FO . . . . .9	W31 . . . . .26	W72 . . . . .24	W189 . . . . .35
SF-2/SFX-2 . . . . .5	W32 . . . . .29	W75 . . . . .36	W192 . . . . .21
SFW/SFTW . . . . .5	W33 . . . . .29	W76 . . . . .36	W193 . . . . .21
SFXW/SFXTW . . . . .5	W34 . . . . .28	W80 . . . . .26	W194 . . . . .21
<b>*SP/SPX . . . . .18</b>	W35 . . . . .28	W81 . . . . .26	W195 . . . . .21
T-SF/T-SFN . . . . .7	W36 . . . . .17	W82 . . . . .27	<b>*W300 . . . . .22</b>
T-SFX/T-SFXN . . . . .7	W37 . . . . .17	W83 . . . . .27	<b>*W304 . . . . .23</b>
W3 . . . . .26	W38 . . . . .17	W87 . . . . .30	<b>*W600 . . . . .22</b>
W4 . . . . .24	W39 . . . . .17	W91 . . . . .24	<b>*W604 . . . . .23</b>
W5 . . . . .27	W43 . . . . .19	W104 . . . . .19	
W6 . . . . .25	W44 . . . . .19	W106 . . . . .20	
W7 . . . . .30	W45 . . . . .19	W164 . . . . .33	
W8 . . . . .30	W46 . . . . .20	W165 . . . . .33	

*\*Indicates items new to the catalog.*

### SAE J518 SPLIT/CAPTIVE FLANGES FOR SAE FLANGED HEAD CONNECTION

CD 61 - CD 62 . . . . .5
--------------------------

### FLANGED HEAD FITTINGS

#### FOR PIPE

CD 61 - CD 62 SOCKET WELD . . . . .9
CD 61 NPTF THREAD . . . . .9
CD 61 SAE THREAD . . . . .9
CD 61 BUTT WELD-SCHED 40/SCHED 80/SCHED 160 . . . . .10
CD 62 BUTT WELD-SCHED 80/SCHED 160/SCHED XXS . . . . .11

#### FOR TUBE

CD 61 - CD 62 BRAZE-ON . . . . .7
-----------------------------------

#### FOR PIPE & TUBE

CD 61 - CD 62 FLANGE PLUG . . . . .8
--------------------------------------

### SAE 4 BOLT FLANGES

#### FOR PIPE

500 PSI - CD 61 - CODE 62 FLAT SOCKET WELD . . . . .24
CD 61 - CD 62 NPTF . . . . .19
CD 61 - CD 62 SAE THREAD . . . . .20
CD 61 - CD 62 BSPP THREAD . . . . .21
CD 61 - CD 62 DEEP SOCKET WELD . . . . .26
CD 61 BUTT WELD-SCHED 40/SCHED 80/SCHED 160 . . . . .28
CD 62 BUTT WELD-SCHED 80/SCHED 160/SCHED XXS . . . . .29
CD 61 TANK PILOT . . . . .31
CD 61 - CD 62 BLANKING . . . . .17
CD 61 - CD 62 SPACER BLOCKS WITH GAGE PORT . . . . .14
CD 61 SADDLE . . . . .30
CD 61 ELBOW SOCKET WELD . . . . .34
CD 62 ELBOW SOCKET WELD . . . . .35
CD 61 - CD 62 ELBOW NPTF & SAE THREAD . . . . .33

*\*Indicates items new to the catalog.*

### FOR TUBE

CD 61 - CD 62 FLAT SOCKET WELD . . . . .25
CD 61 - CD 62 DEEP SOCKET WELD . . . . .27
CD 61 SADDLE WELD . . . . .30
CD 61 ELBOW SOCKET WELD . . . . .34
CD 62 ELBOW SOCKET WELD . . . . .35
<b>*CD 61 - CD 62 MALE JIC . . . . .22</b>
<b>*CD 61 - CD 62 MALE ORFS . . . . .23</b>

### SQUARE 4 BOLT FLANGES

#### FOR PIPE

3000 SERIES FLAT SOCKET WELD . . . . .36
3000 SERIES NPTF THREAD . . . . .36

### MISCELLANEOUS COMPONENTS

#### FOR PIPE & TUBE

CD 61 - CD 62 CONNECTOR PLATES . . . . .12
CD 61 - CD 62 CONNECTOR BLOCKS . . . . .12
CD 61 - CD 62 TEE JUNCTION BLOCK . . . . .32
<b>*CD 61 - CD 62 SPLIT FLANGES FOR CAT HOSE . . . . .6</b>
<b>*CD 61 - CD 62 DOUBLE O-RING UNION . . . . .13</b>
<b>*CD 61 - CD 62 ORIFICE PLATE . . . . .15</b>
<b>*CD 61 - CD 62 BOLT PATTERN ADAPTER . . . . .16</b>
<b>*CD 61 - CD 62 SHIPPING PLATES . . . . .18</b>
O-RINGS . . . . .48

## Stainless Steel

### ALPHA-NUMERIC LISTING

SF-2/SFX-2 . . . . .	38	W43 . . . . .	39
SFW/SFTW . . . . .	38	W44 . . . . .	39
SFXW/SFXTW . . . . .	38	W45 . . . . .	39
W4 . . . . .	41	W46 . . . . .	40
W16 . . . . .	46	W48 . . . . .	40
W17 . . . . .	46	W49 . . . . .	40
W18 . . . . .	46	W59 . . . . .	41
W19 . . . . .	46	W60 . . . . .	41
W23 . . . . .	43	W61 . . . . .	41
W24 . . . . .	43	W65 . . . . .	47
W25 . . . . .	43	W66 . . . . .	47
W26 . . . . .	44	W72 . . . . .	41
W27 . . . . .	43	W75 . . . . .	47
W28 . . . . .	44	W76 . . . . .	47
W29 . . . . .	44	W91 . . . . .	41
W30 . . . . .	44	W104 . . . . .	39
W32 . . . . .	44	W106 . . . . .	40
W33 . . . . .	44	W169 . . . . .	45
W34 . . . . .	43	W176 . . . . .	45
W35 . . . . .	43	W186 . . . . .	45
W36 . . . . .	42	W189 . . . . .	45
W37 . . . . .	42		
W38 . . . . .	42		
W39 . . . . .	42		

### SAE J518 SPLIT/CAPTIVE FLANGES FOR SAE FLANGED HEAD CONNECTION

CODE 61 - CODE 62 . . . . .38

### SAE 4 BOLT FLANGES

#### FOR PIPE

500 PSI - CODE 61 - CODE 62 FLAT SOCKET . . . . .41

CODE 61 - CODE 62 NPTF . . . . .39

CODE 61 - CODE 62 SAE THREAD . . . . .40

CODE 61 BUTT WELD-SCHED 40/SCHED 80/SCHED 160 . . . .43

CODE 62 BUTT WELD-SCHED 80/SCHED 160/SCHED XXS . .44

CODE 61 - CODE 62 BLANKING . . . . .42

CODE 61 - CODE 62 ELBOW SOCKET WELD . . . . .45

### SQUARE 4 BOLT FLANGES

#### FOR PIPE

3000 SERIES FLAT SOCKET WELD . . . . .47

3000 SERIES NPTF THREAD . . . . .47

### MISCELLANEOUS COMPONENTS

#### FOR PIPE & TUBE

CODE 61 - CODE 62 TEE JUNCTION BLOCK . . . . .46

*\*THE USE OF STAINLESS STEEL BOLTS MAY REDUCE THE PRESSURE RATING OF THE ASSEMBLY.*

## Ordering System

Our basic part numbering system is simple to use. The explanation of our part numbering system is detailed below. The series number provides the greatest amount of information pertaining to the flange product. The port size and pad size simply refer to size only, with all sizes based on 1/16 of an inch.

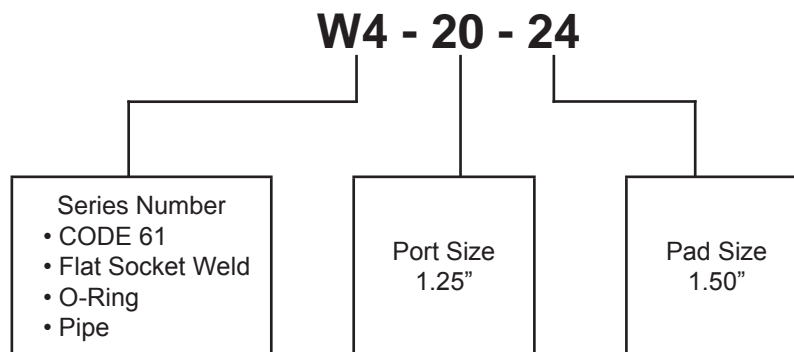

NOTE #1 – All items available with mounting kit by simply adding suffix letter “U”.

NOTE #2 – All items available in stainless steel material by simply adding the suffix letters “SS”.

NOTE #3 – All items available with metric mounting holes simply by adding the appropriate suffix (IE: M10, M12, etc.).

## Pressure Ratings of SAE Flanges

STANDARD PRESSURE: J518 CODE 61

HIGH PRESSURE: J518 CODE 62

SIZE	PSI	BAR	BOLT TORQUE
			lb-in
1/2"	5000	350	175-225
3/4"	5000	350	250-350
1"	5000	350	325-425
1 1/4"	4000	280	425-550
1 1/2"	3000	210	550-700
2"	3000	210	650-800
2 1/2"	2500	170	950-1100
3"	2000	140	1650-1800
3 1/2"	500	35	1400-1600
4"	500	35	1400-1600
5"	500	35	1400-1600

SIZE	PSI	BAR	BOLT TORQUE
			lb-in
3/4"	6000	420	300-400
1"	6000	420	500-600
1 1/4"	6000	420	750-900
1 1/2"	6000	420	1400-1600
2"	6000	420	2400-2600

## Split Flange Clamp

### 1 Clean the sealing surface

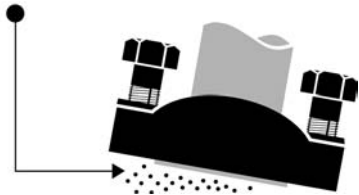

Clean the sealing surface and make certain the O-Ring groove is free of chips, dirt, nicks, etc. Foreign material prevents a proper seal.

### 2 Make sure of full flange-to-head contact.



Check O-Ring to see that it is properly seated to prevent cutting during installation. Push clamp halves inward as far as they will go so as to give greatest possible bearing area necessary to long service life.

### 3 Tighten bolts evenly and torque to specs



This ensures even distribution of the necessary sealing forces on the clamps and O-Ring head.

Anchor's Split-Flange Clamp design gives you a tilt proof clamp. By locating the plane of the Split-Flange Clamp half bolt centerlines so that it passes through the center of force of the flanged head on the Split-Flange Clamp half, unbalanced moments are eliminated. This design principle prevents tilting of the clamp half and extrusion of the O-Ring. It conforms to SAE Standard J518.



Hose assembly removal is facilitated by the rounded end design of the clamp halves. Loosening of the four bolts and removal of one bolt permits the end of one clamp half to be pivoted to the side about the other bolt. This opens the clamp fully and allows the flanged head assembly to be removed. It also allows the easy assembly of the hose in close quarters.

Use of the highly efficient and widely used static O-Ring seal eliminates the use of gaskets, tapered threads and sealing compounds. There are no spiral leakage paths. The connector may be assembled with small automotive wrenches in tight quarters with low torque requirements. Large wrenches and high assembly forces are not required.

# Carbon Steel

**Anchor Fluid Power manufactures many reduced size, custom, and metric flanges that are not listed in our catalog. For flanges not listed in the catalog, please consult the factory for availability.**

CODE 61 SPLIT FLANGE													
PART NO.	**KIT PART NO.	FLANGE SIZE	A	B	C	D	E	F	G	H	J	MOUNTING HARDWARE	
												O-RING	HHCS
8SF-2	8SFO	.50	.86	2.12	1.500	.75	.50	1.219	.955	.245	.344	210	5/16-18X1.25
12SF-2	12SFO	.75	.98	2.56	1.875	.88	.56	1.531	1.265	.245	.406	214	3/8-16X1.25
16SF-2	16SFO	1.00	1.11	2.75	2.062	.94	.62	1.781	1.515	.295	.406	219	3/8-16X1.25
20SF-2	20SFO	1.25	1.39	3.12	2.312	.88	.56	2.031	1.720	.295	.469	222	7/16-14X1.50
24SF-2	24SFO	1.50	1.58	3.69	2.750	1.00	.62	2.406	2.000	.295	.531	225	1/2-13X1.50
32SF-2	32SFO	2.00	1.86	4.00	3.062	1.03	.62	2.844	2.470	.355	.531	228	1/2-13X1.50
40SF-2	40SFO	2.50	2.09	4.50	3.500	1.50	.75	3.344	2.950	.355	.531	232	1/2-13X1.75
48SF-2	48SFO	3.00	2.53	5.31	4.188	1.62	.88	4.031	3.580	.355	.656	237	5/8-11X1.75
56SF-2	56SFO	3.50	2.70	6.00	4.750	1.12	.88	4.531	4.030	.422	.656	241	5/8-11X2.00
64SF-2	64SFO	4.00	2.95	6.38	5.125	1.38	1.00	5.031	4.530	.422	.656	245	5/8-11X2.00

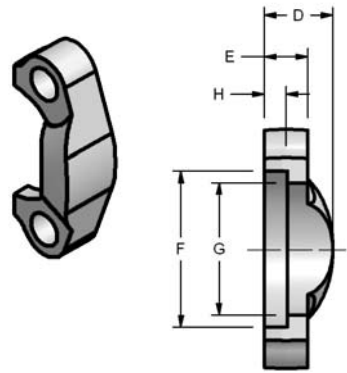

CODE 62 SPLIT FLANGE													
PART NO.	**KIT PART NO.	FLANGE SIZE	A	B	C	D	E	F	G	H	J	MOUNTING HARDWARE	
												O-RING	HHCS
8SFX-2	8SFXO	.50	.89	2.22	1.594	.88	.62	1.281	.970	.285	.344	210	5/16-18X1.25
12SFX-2	12SFXO	.75	1.14	2.81	2.000	1.12	.75	1.656	1.280	.325	.406	214	3/8-16X1.50
16SFX-2	16SFXO	1.00	1.33	3.19	2.250	1.31	.94	1.906	1.530	.355	.469	219	7/16-14X1.75
20SFX-2	20SFXO	1.25	1.48	3.75	2.625	1.50	1.06	2.156	1.750	.385	.531	222	1/2-13X1.75
24SFX-2	24SFXO	1.50	1.83	4.44	3.125	1.69	1.19	2.531	2.030	.475	.656	225	5/8-11X2.25
32SFX-2	32SFXO	2.00	2.20	5.25	3.812	2.06	1.44	3.156	2.660	.475	.781	228	3/4-10X2.75

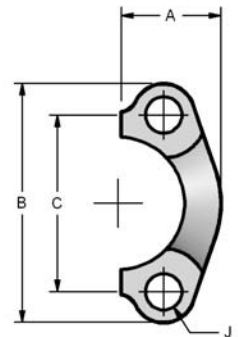

\*\*When ordering this part # you will receive:(2) split flange halves, (4) hex head screws and lockwashers, and (1) Buna N O-Ring

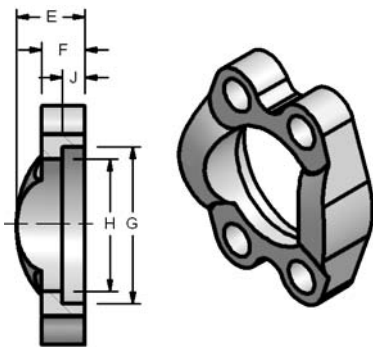

CODE 61 CAPTIVE FLANGE															
DRILLED PART NO.	TAPPED PART NO.	FLANGE SIZE	A	B	C	D	E	F	G	H	J	K	K UNC-2B		
8SFW	8SFTW	.50	1.81	2.12	.688	1.500	.75	.50	1.219	.955	.245	.344	5/16-18		
12SFW	12SFTW	.75	2.06	2.56	.875	1.875	.88	.56	1.531	1.265	.245	.406	3/8-16		
16SFW	16SFTW	1.00	2.31	2.75	1.031	2.062	.94	.62	1.781	1.515	.295	.406	3/8-16		
20SFW	20SFTW	1.25	2.88	3.12	1.188	2.312	.88	.56	2.031	1.720	.295	.469	7/16-14		
24SFW	24SFTW	1.50	3.25	3.69	1.406	2.750	1.00	.62	2.406	2.000	.295	.531	1/2-13		
32SFW	32SFTW	2.00	3.81	4.00	1.688	3.062	1.03	.62	2.844	2.470	.355	.531	1/2-13		
40SFW	40SFTW	2.50	4.28	4.50	2.000	3.500	1.50	.75	3.344	2.950	.355	.531	1/2-13		
48SFW	48SFTW	3.00	5.16	5.31	2.438	4.188	1.62	.88	4.031	3.580	.355	.656	5/8-11		
56SFW	56SFTW	3.50	5.50	6.00	2.750	4.750	1.12	.88	4.531	4.030	.422	.656	5/8-11		
64SFW	64SFTW	4.00	6.00	6.38	3.062	5.125	1.38	1.00	5.031	4.530	.422	.656	5/8-11		

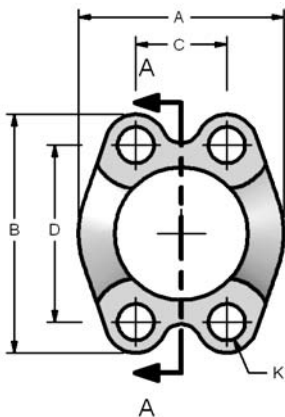

CODE 62 CAPTIVE FLANGE															
DRILLED PART NO.	TAPPED PART NO.	FLANGE SIZE	A	B	C	D	E	F	G	H	J	K	K UNC-2B		
8SFXW	8SFXTW	.50	1.86	2.22	.718	1.594	.88	.62	1.281	.970	.285	.344	5/16-18		
12SFXW	12SFXTW	.75	2.38	2.81	.937	2.000	1.12	.75	1.656	1.280	.325	.406	3/8-16		
16SFXW	16SFXTW	1.00	2.75	3.19	1.093	2.250	1.31	.94	1.906	1.530	.355	.469	7/16-14		
20SFXW	20SFXTW	1.25	3.06	3.75	1.250	2.625	1.50	1.06	2.156	1.750	.385	.531	1/2-13		
24SFXW	24SFXTW	1.50	3.75	4.44	1.437	3.125	1.69	1.19	2.531	2.030	.475	.656	5/8-11		
32SFXW	32SFXTW	2.00	4.50	5.25	1.750	3.812	2.06	1.44	3.156	2.660	.475	.781	3/4-10		

# Split Flange

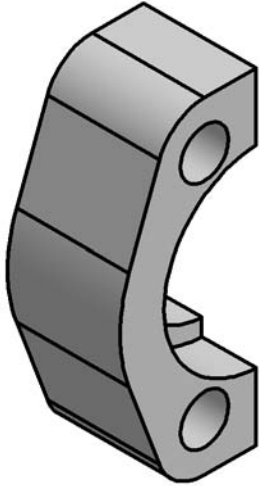

**Fits Caterpillar Flange Head hose ends.**

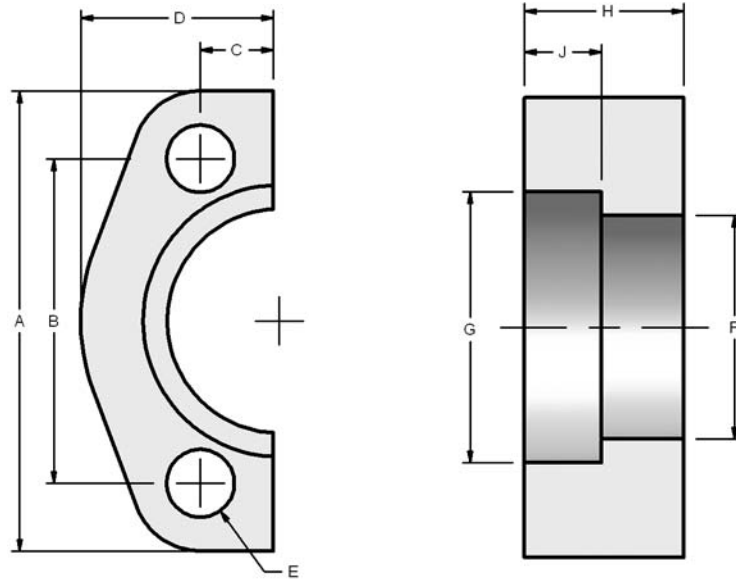

PTX SERIES SPLIT FLANGES												
PART NO.	**KIT PART NO.	FLANGE SIZE	A	B	C	D	E	F	G	H	J	MOUNTING HARDWARE HHCS
12PTX-2	12PTXO	.75	2.950	2.000	.446	1.210	.406	1.270	1.632	1.102	.530	3/8-16X1.75
16PTX-2	16PTXO	1.00	3.190	2.250	.507	1.335	.469	1.550	1.884	1.102	.530	7/16-14X1.75
20PTX-2	20PTXO	1.25	3.750	2.625	.585	1.490	.531	1.705	2.134	1.102	.530	1/2-13X2.00
24PTX-2	24PTXO	1.50	4.440	3.125	.679	1.335	.656	2.080	2.509	1.258	.530	5/8-11X2.50
32PTX-2	32PTXO	2.00	5.240	3.812	.834	2.205	.827	2.640	3.130	1.457	.530	3/4-10X2.75

\*\*When ordering this part # you will receive:(2) split flange halves, (4) hex head bolts and lockwashers. **NO O-RING INCLUDED.**

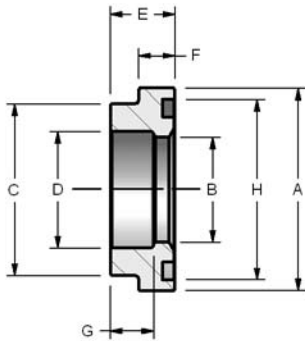

Figure 1

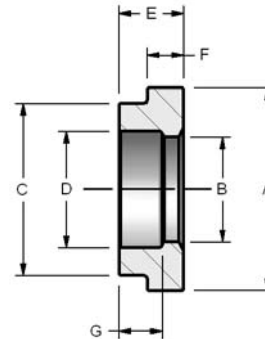
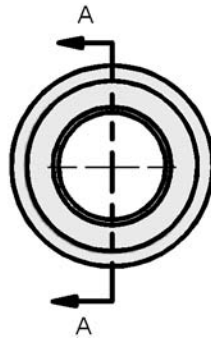

Figure 2

\*For sizes not listed, please consult factory.

CODE 61 TUBE FLANGE HEAD FITTING											
PART NO. O-RING FIG. 1	PART NO. FLAT FACE FIG. 2	TUBE SIZE	FLANGE SIZE	A	B	C	D	E	F	G	H
8T-8SF	8T-8SFN	.50	.50	1.188	.406	.924	.502	.50	.265	.312	1.000
10T-8SF	10T-8SFN	.63	.50	1.188	.500	.924	.627	.50	.265	.312	1.000
12T-12SF	12T-12SFN	.75	.75	1.500	.656	1.234	.752	.56	.265	.375	1.250
16T-12SF	16T-12SFN	1.00	.75	1.500	.750	1.234	1.002	.56	.265	.375	1.250
16T-16SF	16T-16SFN	1.00	1.00	1.750	.906	1.484	1.002	.56	.315	.375	1.560
20T-16SF	20T-16SFN	1.25	1.00	1.750	1.000	1.484	1.252	.56	.315	.375	1.560
20T-20SF	20T-20SFN	1.25	1.25	2.000	1.125	1.684	1.252	.56	.315	.375	1.750
24T-20SF	24T-20SFN	1.50	1.25	2.000	1.250	1.684	1.502	.56	.315	.375	1.750
24T-24SF	24T-24SFN	1.50	1.50	2.375	1.375	1.964	1.502	.62	.315	.438	2.115
28T-24SF	28T-24SFN	1.75	1.50	2.375	1.500	1.964	1.752	.62	.315	.438	2.115
32T-32SF	32T-32SFN	2.00	2.00	2.812	1.875	2.434	2.002	.62	.375	.500	2.490
36T-32SF	36T-32SFN	2.25	2.00	2.812	2.000	2.434	2.252	.62	.375	.500	2.490
40T-40SF	40T-40SFN	2.50	2.50	3.312	2.375	2.904	2.502	.68	.375	.562	2.995
44T-40SF	44T-40SFN	2.75	2.50	3.312	2.500	2.904	2.752	.68	.375	.500	2.995
48T-48SF	48T-48SFN	3.00	3.00	4.000	2.875	3.534	3.002	.75	.375	.562	3.615

CODE 62 TUBE FLANGE HEAD FITTING											
PART NO. O-RING FIG. 1	PART NO. FLAT FACE FIG. 2	TUBE SIZE	FLANGE SIZE	A	B	C	D	E	F	G	H
12T-12SFX	12T-12SFXN	.75	.75	1.625	.656	1.234	.752	.69	.345	.500	1.250
16T-12SFX	16T-12SFXN	1.00	.75	1.625	.750	1.234	1.002	.69	.345	.500	1.250
16T-16SFX	16T-16SFXN	1.00	1.00	1.875	.810	1.484	1.002	.81	.375	.625	1.560
20T-16SFX	20T-16SFXN	1.25	1.00	1.875	1.000	1.484	1.252	.81	.375	.625	1.560
20T-20SFX	20T-20SFXN	1.25	1.25	2.125	1.010	1.704	1.252	1.00	.405	.812	1.750
24T-20SFX	24T-20SFXN	1.50	1.25	2.125	1.250	1.704	1.502	1.00	.405	.812	1.750
24T-24SFX	24T-24SFXN	1.50	1.50	2.500	1.250	1.984	1.502	1.19	.495	1.000	2.115
28T-24SFX	28T-24SFXN	1.75	1.50	2.500	1.500	1.984	1.757	1.19	.495	1.000	2.115
32T-32SFX	32T-32SFXN	2.00	2.00	3.125	1.750	2.604	2.002	1.50	.495	1.375	2.490
36T-32SFX	36T-32SFXN	2.25	2.00	3.125	2.000	2.604	2.252	1.50	.495	1.312	2.490

# Flange Plug

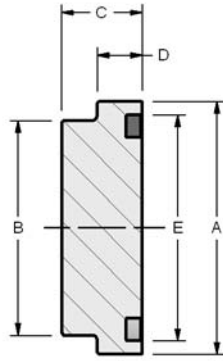
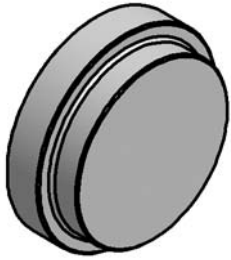

Figure 1

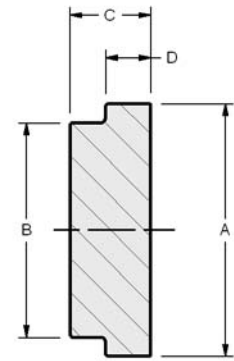
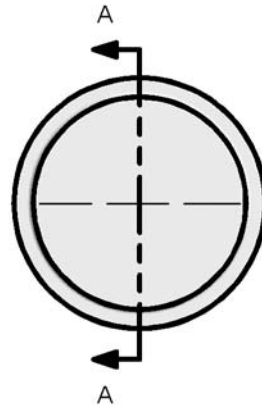

Figure 2

## CODE 61 FLANGE PLUG

PART NO. O-RING FIG. 1	PART NO. FLAT FACE FIG. 2	FLANGE SIZE	A	B	C	D	E
8-FOP	8-FP	.50	1.188	.924	.50	.265	1.000
12-FOP	12-FP	.75	1.500	1.234	.56	.265	1.250
16-FOP	16-FP	1.00	1.750	1.484	.56	.315	1.560
20-FOP	20-FP	1.25	2.000	1.684	.56	.315	1.750
24-FOP	24-FP	1.50	2.375	1.964	.62	.315	2.115
32-FOP	32-FP	2.00	2.810	2.434	.62	.375	2.490
40-FOP	40-FP	2.50	3.312	2.904	.68	.375	2.995
48-FOP	48-FP	3.00	4.000	3.534	.75	.375	3.615

## CODE 62 FLANGE PLUG

PART NO. O-RING FIG. 1	PART NO. FLAT FACE FIG. 2	FLANGE SIZE	A	B	C	D	E
12-FOPX	12-FPX	.75	1.625	1.234	.690	.345	1.250
16-FOPX	16-FPX	1.00	1.875	1.484	.810	.375	1.560
20-FOPX	20-FPX	1.25	2.125	1.704	1.000	.405	1.750
24-FOPX	24-FPX	1.50	2.500	1.984	1.190	.495	2.115
32-FOPX	32-FPX	2.00	3.125	2.604	1.500	.495	2.490

# Female Flange Head Adapter

CODE 61 SOCKET WELD TO FLANGE HEAD FOR PIPE											
PART NO.	PIPE SIZE	CLAMP SIZE	A	B	C	D	E	F	G	H	J
8P-8WSF	.50	.50	2.34	.56	.265	1.187	1.000	.500	1.25	.855	.924
12P-12WSF	.75	.75	2.34	.56	.265	1.500	1.250	.750	1.50	1.062	1.234
16P-16WSF	1.00	1.00	2.38	.63	.315	1.750	1.560	1.000	1.75	1.328	1.484
20P-20WSF	1.25	1.25	2.62	.68	.315	2.000	1.750	1.250	2.00	1.672	1.684
24P-24WSF	1.50	1.50	2.88	.76	.315	2.375	2.115	1.500	2.38	1.922	1.964
32P-32WSF	2.00	2.00	3.00	.88	.375	2.812	2.490	2.000	2.81	2.406	2.434
40P-40WSF	2.50	2.50	3.06	1.00	.375	3.312	2.995	2.500	3.31	2.906	2.920
48P-48WSF	3.00	3.00	3.88	1.25	.375	4.000	3.615	2.875	4.00	3.547	3.534

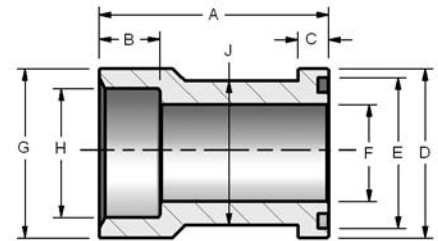

CODE 62 SOCKET WELD TO FLANGE HEAD FOR PIPE											
PART NO.	PIPE SIZE	CLAMP SIZE	A	B	C	D	E	F	G	H	J
W53-12-12	.75	.75	2.75	.630	.345	1.625	1.250	.750	1.750	1.062	1.234
W53-16-16	1.00	1.00	3.06	.630	.375	1.875	1.560	1.000	2.000	1.328	1.484
W53-20-20	1.25	1.25	3.31	.690	.405	2.125	1.750	1.125	2.312	1.672	1.704
W53-24-24	1.50	1.50	3.93	.750	.495	2.500	2.115	1.375	2.750	1.922	1.984
W53-32-32	2.00	2.00	4.06	.880	.495	3.125	2.490	1.875	3.125	2.406	2.604

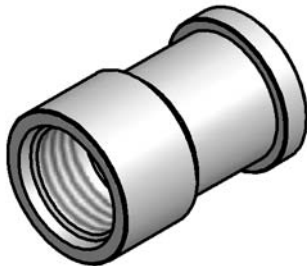

CODE 61 NPTF THREAD TO FLANGE HEAD										
PART NO.	PIPE SIZE	CLAMP SIZE	A	B	C	D	E	F	G NPTF	H
12F-12FO	.75	.75	2.47	.265	1.500	1.250	.75	1.50	.75	1.234
16F-16FO	1.00	1.00	2.66	.315	1.750	1.560	1.00	1.75	1.00	1.484
20F-20FO	1.25	1.25	2.84	.315	2.000	1.750	1.25	2.00	1.25	1.684
24F-24FO	1.50	1.50	3.00	.315	2.375	2.115	1.50	2.38	1.50	1.964
32F-32FO	2.00	2.00	3.00	.375	2.812	2.490	2.00	2.81	2.00	2.434

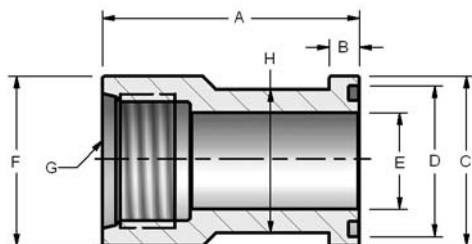

CODE 61 SAE THREAD TO FLANGE HEAD										
PART NO.	TUBE SIZE	CLAMP SIZE	A	B	C	D	E	F	G UN-2B	H
12S-12FO	.75	.75	2.47	.265	1.500	1.250	.75	1.50	1 1/16-12	1.234
16S-16FO	1.00	1.00	2.66	.315	1.750	1.560	1.00	1.75	1 5/16-12	1.484
20S-20FO	1.25	1.25	2.84	.315	2.000	1.750	1.25	2.00	1 5/8-12	1.684
24S-24FO	1.50	1.50	3.00	.315	2.375	2.115	1.50	2.38	1 7/8-12	1.964
32S-32FO	2.00	2.00	3.00	.375	2.812	2.490	2.00	2.81	2 1/2-12	2.434

# Butt Weld Flange Head

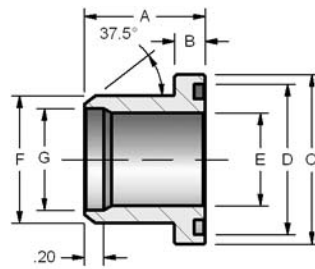

Figure 1

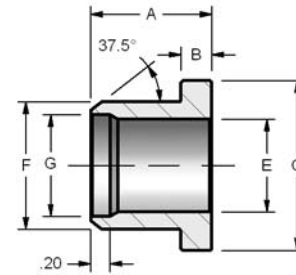

Figure 2

## CODE 61 BUTT WELD TO FLANGE HEAD FOR SCHEDULE 40 PIPE

PART NO. O-RING FIG. 1	PART NO. FLAT FACE FIG. 2	PIPE SIZE	CLAMP SIZE	A	B	C	D	E	F	G
8P-8BWSF-40	8P-8BWSFN-40	.50	.50	1.06	.265	1.188	1.000	.548	.840	.624
12P-12BWSF-40	12P-12BWSFN-40	.75	.75	1.06	.265	1.500	1.250	.744	1.050	.826
16P-16BWSF-40	16P-16BWSFN-40	1.00	1.00	1.25	.315	1.750	1.560	.959	1.315	1.051
20P-20BWSF-40	20P-20BWSFN-40	1.25	1.25	1.44	.315	2.000	1.750	1.280	1.660	1.382
24P-24BWSF-40	24P-24BWSFN-40	1.50	1.50	1.75	.315	2.375	2.115	1.502	1.900	1.612
32P-32BWSF-40	32P-32BWSFN-40	2.00	2.00	2.00	.375	2.812	2.490	1.941	2.375	2.069
40P-40BWSF-40	40P-40BWSFN-40	2.50	2.50	2.31	.375	3.312	2.995	2.325	2.875	2.471
48P-48BWSF-40	48P-48BWSFN-40	3.00	3.00	2.32	.375	4.000	3.615	2.902	3.500	3.070

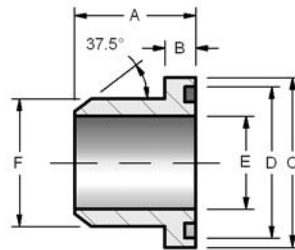

Figure 1

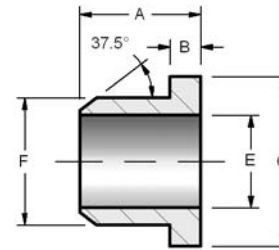

Figure 2

## CODE 61 BUTT WELD TO FLANGE HEAD FOR SCHEDULE 80 PIPE

PART NO. O-RING FIG. 1	PART NO. FLAT FACE FIG. 2	PIPE SIZE	CLAMP SIZE	A	B	C	D	E	F
8P-8BWSF-80	8P-8BWSFN-80	.50	.50	1.06	.265	1.188	1.000	.548	.840
12P-12BWSF-80	12P-12BWSFN-80	.75	.75	1.06	.265	1.500	1.250	.744	1.050
16P-16BWSF-80	16P-16BWSFN-80	1.00	1.00	1.25	.315	1.750	1.560	.959	1.315
20P-20BWSF-80	20P-20BWSFN-80	1.25	1.25	1.44	.315	2.000	1.750	1.280	1.660
24P-24BWSF-80	24P-24BWSFN-80	1.50	1.50	1.75	.315	2.375	2.115	1.502	1.900
32P-32BWSF-80	32P-32BWSFN-80	2.00	2.00	2.00	.375	2.812	2.490	1.941	2.375
40P-40BWSF-80	40P-40BWSFN-80	2.50	2.50	2.31	.375	3.312	2.995	2.325	2.875
48P-48BWSF-80	48P-48BWSFN-80	3.00	3.00	2.32	.375	4.000	3.615	2.902	3.500

## CODE 61 BUTT WELD TO FLANGE HEAD FOR SCHEDULE 160 PIPE

PART NO. O-RING FIG. 1	PART NO. FLAT FACE FIG. 2	PIPE SIZE	CLAMP SIZE	A	B	C	D	E	F
8P-8BWSF-160	8P-8BWSFN-160	.50	.50	1.06	.265	1.188	1.000	.466	.840
12P-12BWSF-160	12P-12BWSFN-160	.75	.75	1.06	.265	1.500	1.250	.614	1.050
16P-16BWSF-160	16P-16BWSFN-160	1.00	1.00	1.25	.315	1.750	1.560	.817	1.315
20P-20BWSF-160	20P-20BWSFN-160	1.25	1.25	1.44	.315	2.000	1.750	1.162	1.660
24P-24BWSF-160	24P-24BWSFN-160	1.50	1.50	1.75	.315	2.375	2.115	1.340	1.900
32P-32BWSF-160	32P-32BWSFN-160	2.00	2.00	2.00	.375	2.812	2.490	1.689	2.375
40P-40BWSF-160	40P-40BWSFN-160	2.50	2.50	2.31	.375	3.312	2.995	2.127	2.875
48P-40BWSF-160	48P-40BWSFN-160	3.00	3.00	2.32	.375	4.000	3.615	2.626	3.500

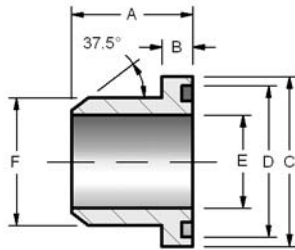

Figure 1

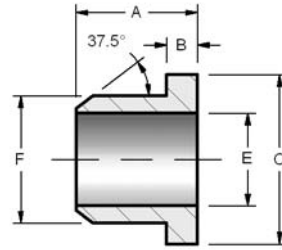

Figure 2

### CODE 62 BUTT WELD TO FLANGE HEAD FOR SCHEDULE 80 PIPE

PART NO. O-RING FIG. 1	PART NO. FLAT FACE FIG. 2	PIPE SIZE	CLAMP SIZE	A	B	C	D	E	F
8P-8BWSFX-80	8P-8BWSFXN-80	.50	.50	1.10	.305	1.250	1.000	.548	.840
12P-12BWSFX-80	12P-12BWSFXN-80	.75	.75	1.42	.345	1.625	1.250	.744	1.050
16P-16BWSFX-80	16P-16BWSFXN-80	1.00	1.00	1.61	.375	1.875	1.560	.959	1.315
20P-20BWSFX-80	20P-20BWSFXN-80	1.25	1.25	1.73	.405	2.125	1.750	1.280	1.660
24P-24BWSFX-80	24P-24BWSFXN-80	1.50	1.50	2.17	.495	2.500	2.115	1.502	1.900
32P-32BWSFX-80	32P-32BWSFXN-80	2.00	2.00	2.48	.495	3.125	2.490	1.941	2.375

### CODE 62 BUTT WELD TO FLANGE HEAD FOR SCHEDULE 160 PIPE

PART NO. O-RING FIG. 1	PART NO. FLAT FACE FIG. 2	PIPE SIZE	CLAMP SIZE	A	B	C	D	E	F
8P-8BWSFX-160	8P-8BWSFXN-160	.50	.50	1.10	.305	1.250	1.000	.466	.840
12P-12BWSFX-160	12P-12BWSFXN-160	.75	.75	1.42	.345	1.625	1.250	.614	1.050
16P-16BWSFX-160	16P-16BWSFXN-160	1.00	1.00	1.61	.375	1.875	1.560	.817	1.315
20P-20BWSFX-160	20P-20BWSFXN-160	1.25	1.25	1.73	.405	2.125	1.750	1.162	1.660
24P-24BWSFX-160	24P-24BWSFXN-160	1.50	1.50	2.17	.495	2.500	2.115	1.340	1.900
32P-32BWSFX-160	32P-32BWSFXN-160	2.00	2.00	2.48	.495	3.125	2.490	1.689	2.375

### CODE 62 BUTT WELD TO FLANGE HEAD FOR SCHEDULE XXS PIPE

PART NO. O-RING FIG. 1	PART NO. FLAT FACE FIG. 2	PIPE SIZE	CLAMP SIZE	A	B	C	D	E	F
8P-8BWSFX-XXS	8P-8BWSFXN-XXS	.50	.50	1.10	.305	1.250	1.000	.254	.840
12P-12BWSFX-XXS	12P-12BWSFXN-XXS	.75	.75	1.42	.345	1.625	1.250	.436	1.050
16P-16BWSFX-XXS	16P-16BWSFXN-XXS	1.00	1.00	1.61	.375	1.875	1.560	.601	1.315
20P-20BWSFX-XXS	20P-20BWSFXN-XXS	1.25	1.25	1.73	.405	2.125	1.750	.898	1.660
24P-24BWSFX-XXS	24P-24BWSFXN-XXS	1.50	1.50	2.17	.495	2.500	2.115	1.102	1.900
32P-32BWSFX-XXS	32P-32BWSFXN-XXS	2.00	2.00	2.48	.495	3.125	2.490	1.505	2.375

# Connector Block & Plate



Used to connect two o-ring flanges.

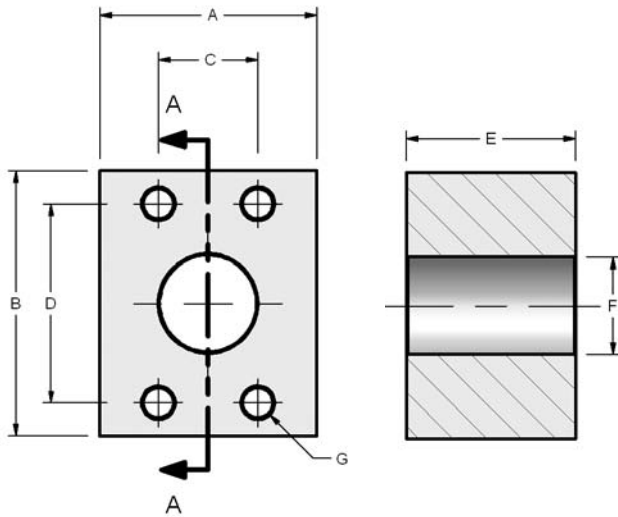
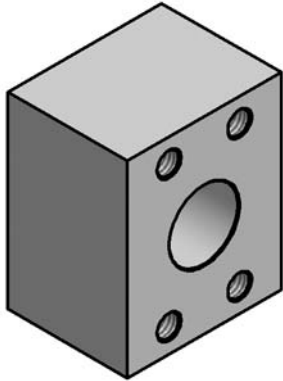

## CODE 61 CONNECTOR BLOCK

PART NO.	PAD SIZE	A	B	C	D	E	F	G UNC-2B
ACB 8-8	.50	2.00	2.12	.688	1.500	1.75	.502	5/16-18
ACB 12-12	.75	2.00	2.62	.875	1.875	1.75	.752	3/8-16
ACB 16-16	1.00	2.25	2.75	1.031	2.062	1.75	1.002	3/8-16
ACB 20-20	1.25	3.00	3.19	1.188	2.312	2.125	1.252	7/16-14
ACB 24-24	1.50	3.50	3.75	1.406	2.750	2.125	1.502	1/2-13
ACB 32-32	2.00	3.88	4.00	1.688	3.062	2.125	1.942	1/2-13
ACB 40-40	2.50	4.38	4.50	2.000	3.500	2.375	2.442	1/2-13

## CODE 62 CONNECTOR BLOCK

PART NO.	PAD SIZE	A	B	C	D	E	F	G UNC-2B
ACBX 8-8	.50	2.00	2.22	.718	1.594	1.75	.502	5/16-18
ACBX 12-12	.75	2.50	2.81	.937	2.000	2.00	.752	3/8-16
ACBX 16-16	1.00	2.75	3.19	1.093	2.250	2.00	1.002	7/16-14
ACBX 20-20	1.25	3.00	3.75	1.250	2.625	2.00	1.252	1/2-13
ACBX 24-24	1.50	3.88	4.50	1.437	3.125	2.50	1.502	5/8-11
ACBX 32-32	2.00	4.50	5.25	1.750	3.812	3.00	1.942	3/4-10

## CODE 61 CONNECTOR PLATE

PART NO.	PAD SIZE	A	B	C	D	E	F
8 CP	.50	1.81	2.12	.688	1.500	.50	.344
12 CP	.75	2.06	2.56	.875	1.875	.75	.406
16 CP	1.00	2.31	2.75	1.031	2.062	1.00	.406
20 CP	1.25	2.88	3.12	1.188	2.312	1.25	.469
24 CP	1.50	3.25	3.69	1.406	2.750	1.50	.531
32 CP	2.00	3.81	4.00	1.688	3.062	2.00	.531
40 CP	2.50	4.12	4.44	2.000	3.500	2.50	.531
48 CP	3.00	5.16	5.31	2.438	4.188	3.00	.656

## CODE 62 CONNECTOR PLATE

PART NO.	PAD SIZE	A	B	C	D	E	F
12 CPX	.75	2.38	2.81	.937	2.000	.750	.406
16 CPX	1.00	2.75	3.19	1.093	2.250	1.000	.469
20 CPX	1.25	3.06	3.75	1.250	2.625	1.250	.531
24 CPX	1.50	3.75	4.44	1.437	3.125	1.500	.656
32 CPX	2.00	4.50	5.25	1.750	3.812	2.000	.781

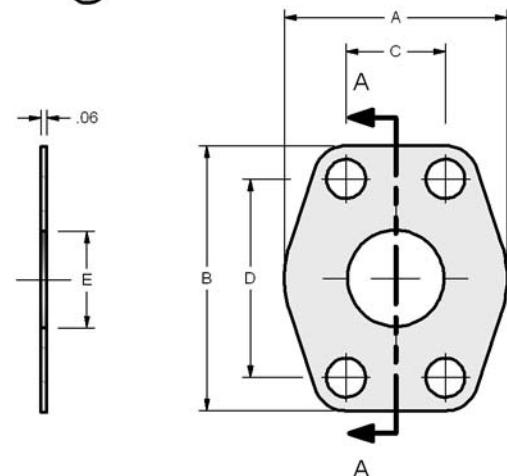

Used to connect two flat faced flanges.

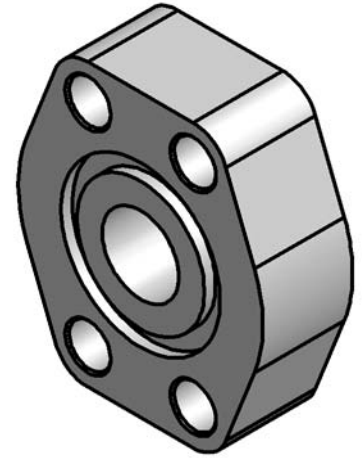
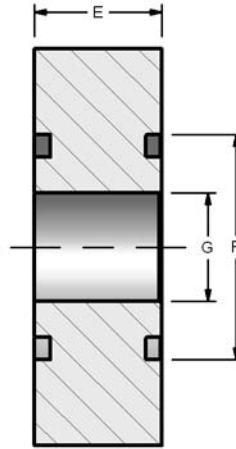
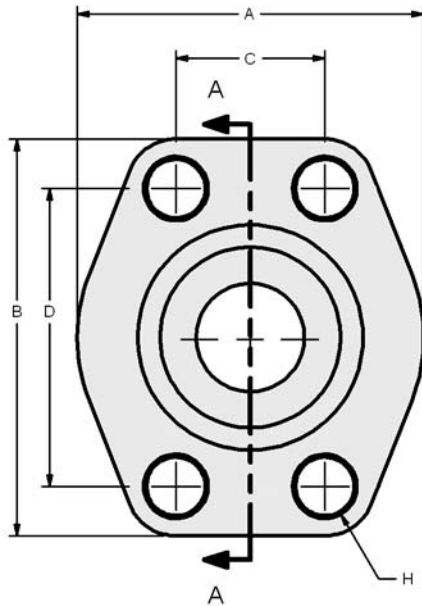

CODE 61 DOUBLE O-RING SPACER									
PART NO.	PAD SIZE	A	B	C	D	E	F	G	H
ADOS-8-8	.50	1.813	2.125	.688	1.50	.750	1.000	.502	.344
ADOS-12-12	.75	2.063	2.563	.875	1.875	.750	1.250	.752	.406
ADOS-16-16	1.00	2.313	2.750	1.031	2.063	.880	1.560	1.002	.406
ADOS-20-20	1.25	2.875	3.125	1.188	2.313	.940	1.750	1.252	.469
ADOS-24-24	1.50	3.250	3.688	1.406	2.750	1.190	2.115	1.502	.531
ADOS-32-32	2.00	3.813	4.000	1.688	3.063	1.44	2.490	2.002	.531
ADOS-40-40	2.50	4.281	4.500	2.000	3.500	1.815	2.995	2.502	.531
ADOS-48-48	3.00	5.156	5.313	2.438	4.188	2.190	3.615	3.002	.656
ADOS-56-56	3.50	5.500	6.000	2.750	4.750	1.440	4.095	3.502	.656
ADOS-64-64	4.00	6.00	6.38	3.062	5.125	1.44	4.595	4.002	.656

CODE 62 DOUBLE O-RING SPACER									
PART NO. O-RING	PAD SIZE	A	B	C	D	E	F	G	H
ADOSX-8-8	.500	1.94	2.30	.718	1.594	1.25	1.000	.502	.344
ADOSX-12-12	.750	2.50	2.95	.937	2.000	1.250	1.250	.752	.406
ADOSX-16-16	1.00	2.75	3.19	1.093	2.250	1.500	1.560	1.002	.492
ADOSX-20-20	1.25	3.06	3.75	1.250	2.625	1.430	1.750	1.252	.531
ADOSX-24-24	1.50	3.75	4.44	1.437	3.125	1.815	2.115	1.502	.656
ADOSX-32-32	2.00	4.50	5.25	1.750	3.812	1.815	2.490	2.002	.781
ADOSX-40-40	2.50	5.87	6.87	2.312	4.875	1.930	2.995	2.502	.906
ADOSX-48-48	3.00	7.00	8.50	2.812	6.000	2.69	3.615	3.002	1.156

# Gage Port Spacer

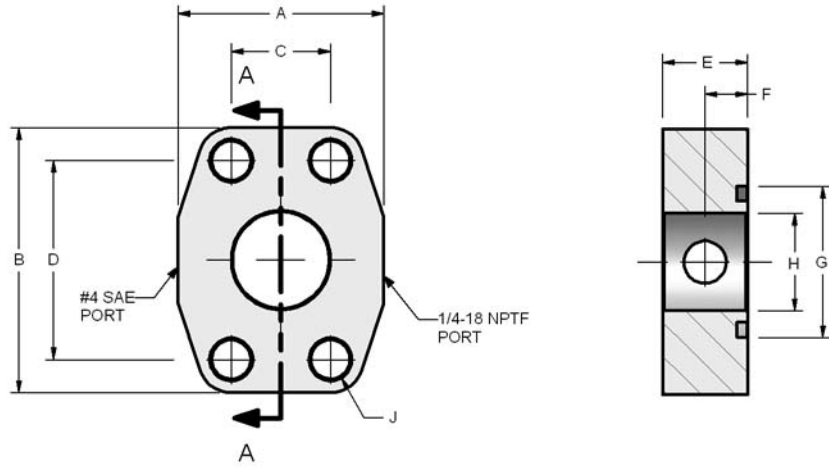
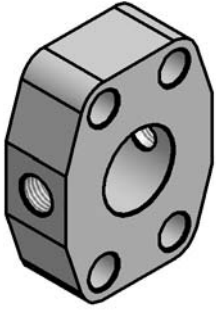

CODE 61 GAGE PORT O-RING SPACER										
PART NO.	PAD SIZE	A	B	C	D	E	F	G	H	J
AS-8-GP	.50	1.82	2.16	.688	1.500	1.25	.62	1.000	.502	.344
AS-12-GP	.75	2.06	2.69	.875	1.875	1.25	.62	1.250	.752	.406
AS-16-GP	1.00	2.31	2.75	1.031	2.062	.88	.44	1.560	1.002	.406
AS-20-GP	1.25	2.87	3.12	1.188	2.312	.94	.47	1.750	1.252	.469
AS-24-GP	1.50	3.25	3.68	1.406	2.750	1.19	.59	2.115	1.502	.531
AS-32-GP	2.00	3.81	4.00	1.688	3.062	1.38	.69	2.490	2.002	.531
AS-40-GP	2.50	4.28	4.50	2.000	3.500	1.75	.88	2.995	2.502	.531
AS-48-GP	3.00	5.15	5.31	2.438	4.188	2.12	1.06	3.615	3.002	.656

CODE 62 GAGE PORT O-RING SPACER										
PART NO.	PAD SIZE	A	B	C	D	E	F	G	H	J
ASX-8-GP	.50	1.94	2.30	.718	1.594	1.25	.62	1.000	.502	.344
ASX-12-GP	.75	2.50	2.95	.937	2.000	1.25	.62	1.250	.752	.406
ASX-16-GP	1.00	2.75	3.19	1.093	2.250	1.50	.75	1.560	1.002	.492
ASX-20-GP	1.25	3.06	3.75	1.250	2.625	1.50	.75	1.750	1.252	.531
ASX-24-GP	1.50	3.75	4.44	1.437	3.125	1.75	.88	2.115	1.502	.656
ASX-32-GP	2.00	4.50	5.25	1.750	3.812	1.75	.88	2.490	2.002	.781
ASX-40-GP	2.50	5.87	6.87	2.312	4.875	2.06	1.03	2.995	2.502	.906
ASX-48-GP	3.00	7.00	8.50	2.812	6.000	2.62	1.31	3.615	3.002	1.156

CODE 61 ORIFICE PLATE									
PART NO.	PAD SIZE	A	B	C	D	E	F	G	H DIA.
AOP-___-0861	.50	1.81	2.12	.688	1.500	.33	1.000	.344	CUSTOMER SPECIFIED
AOP-___-1261	.75	2.06	2.56	.875	1.875	.33	1.250	.413	
AOP-___-1661	1.00	2.31	2.75	1.031	2.063	.33	1.560	.413	
AOP-___-2061	1.25	2.88	3.12	1.188	2.313	.33	1.750	.469	
AOP-___-2461	1.50	3.25	3.69	1.406	2.750	.33	2.115	.531	
AOP-___-3261	2.00	3.81	4.00	1.688	3.063	.33	2.490	.531	
AOP-___-4061	2.50	4.28	4.50	2.000	3.500	.33	2.995	.531	
AOP-___-4861	3.00	5.16	5.31	2.438	4.188	.33	3.615	.656	
AOP-___-5661	3.50	5.50	6.00	2.750	4.750	.33	4.095	.656	
AOP-___-6461	4.00	6.00	6.38	3.062	5.125	.33	4.595	.656	

CODE 62 ORIFICE PLATE									
PART NO.	PAD SIZE	A	B	C	D	E	F	G	H DIA.
AOPX-___-0862	.50	1.94	2.19	.718	1.594	.33	1.000	.354	CUSTOMER SPECIFIED
AOPX-___-1262	.75	2.50	2.81	.937	2.000	.33	1.250	.433	
AOPX-___-1662	1.00	2.75	3.19	1.093	2.250	.33	1.560	.531	
AOPX-___-2062	1.25	3.06	3.75	1.250	2.625	.33	1.750	.610	
AOPX-___-2462	1.50	3.75	4.44	1.437	3.125	.33	2.115	.689	
AOPX-___-3262	2.00	4.50	5.25	1.750	3.812	.33	2.490	.866	

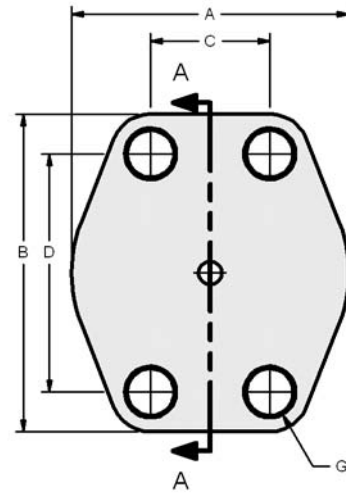
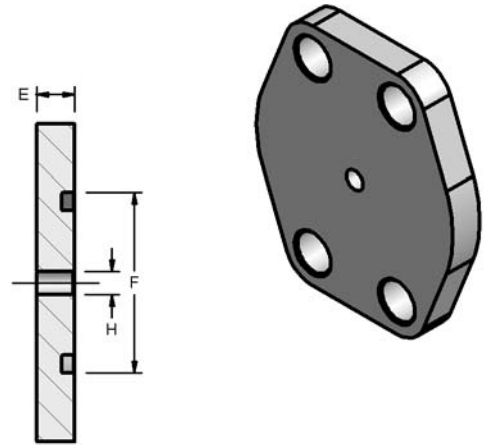

## Ordering Information

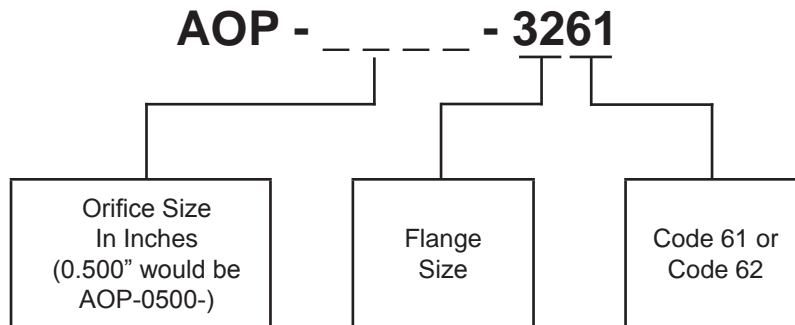

# Bolt Pattern Adapters

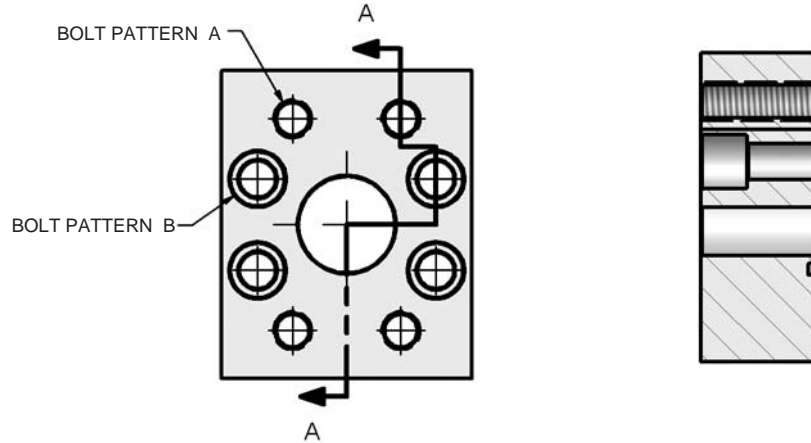
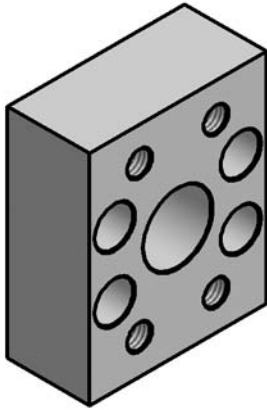

\*Outer envelope shape may vary due to size configuration.

## Ordering Information

**AFA - 1261 - 3262**

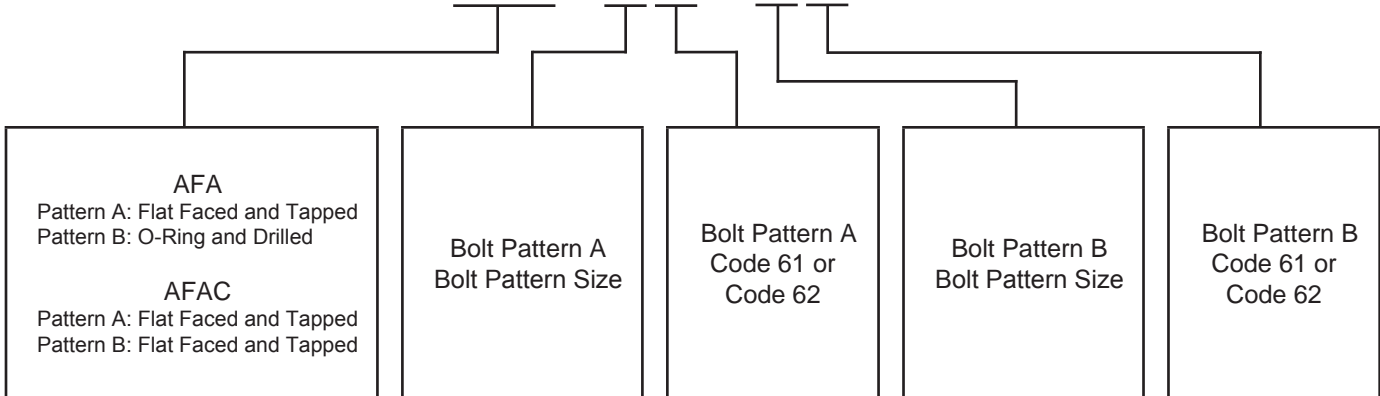

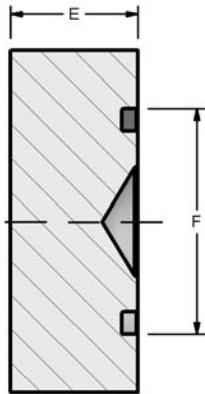

Figure 1

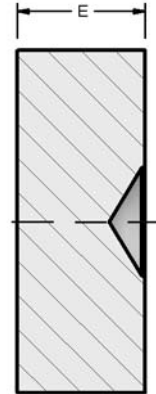
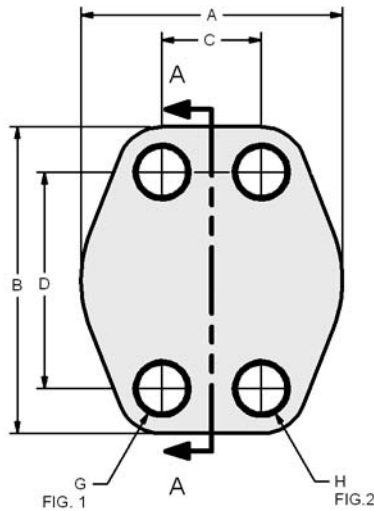
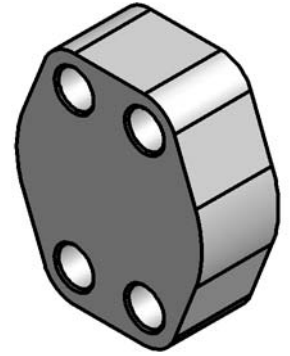

Figure 2



CODE 61 BLANKING												
PART NO. O-RING FIG. 1	PART NO. FLAT FACE FIG. 2	PAD SIZE	A	B	C	D	E	F	G	H UNC-2B	MOUNTING HARDWARE	
											O-RING	SHCS
W36-8-8	W37-8-8	.50	1.813	2.125	.688	1.50	.75	1.000	.344	5/16-18	210	5/16-18X1.50
W36-12-12	W37-12-12	.75	2.063	2.563	.875	1.875	.75	1.250	.406	3/8-16	214	3/8-16X1.50
W36-16-16	W37-16-16	1.00	2.313	2.750	1.031	2.063	.88	1.560	.406	3/8-16	219	3/8-16X1.75
W36-20-20	W37-20-20	1.25	2.875	3.125	1.188	2.313	.94	1.750	.469	7/16-14	222	7/16-14X1.75
W36-24-24	W37-24-24	1.50	3.250	3.688	1.406	2.750	1.19	2.115	.531	1/2-13	225	1/2-13X2.25
W36-32-32	W37-32-32	2.00	3.813	4.000	1.688	3.063	1.44	2.490	.531	1/2-13	228	1/2-13X2.50
W36-40-40	W37-40-40	2.50	4.281	4.500	2.000	3.500	1.82	2.995	.531	1/2-13	232	1/2-13X2.75
W36-48-48	W37-48-48	3.00	5.156	5.313	2.438	4.188	2.19	3.615	.656	5/8-11	237	5/8-11X3.50
W36-56-56	W37-56-56	3.50	5.500	6.000	2.750	4.750	1.44	4.095	.656	5/8-11	241	5/8-11X2.75
W36-64-64	W37-64-64	4.00	6.00	6.38	3.062	5.125	1.44	4.595	.656	5/8-11	245	5/8-11X2.75

CODE 62 BLANKING												
PART NO. O-RING FIG. 1	PART NO. FLAT FACE FIG. 2	PAD SIZE	A	B	C	D	E	F	G	H UNC-2B	MOUNTING HARDWARE	
											O-RING	SHCS
W38-8-8	W39-8-8	.500	1.94	2.30	.718	1.594	1.25	1.000	.344	5/16-18	210	5/16-18X2.00
W38-12-12	W39-12-12	.750	2.50	2.95	.937	2.000	1.25	1.250	.406	3/8-16	214	3/8-16X2.00
W38-16-16	W39-16-16	1.00	2.75	3.19	1.093	2.250	1.50	1.560	.492	7/16-14	219	7/16-14X2.50
W38-20-20	W39-20-20	1.25	3.06	3.75	1.250	2.625	1.43	1.750	.531	1/2-13	222	1/2-13X2.50
W38-24-24	W39-24-24	1.50	3.75	4.44	1.437	3.125	1.82	2.115	.656	5/8-11	225	5/8-11X3.00
W38-32-32	W39-32-32	2.00	4.50	5.25	1.750	3.812	1.82	2.490	.781	3/4-10	228	3/4-10X3.00
W38-40-40	W39-40-40	2.50	5.87	6.87	2.312	4.875	1.93	2.995	.906	7/8-9	232	7/8-9X3.50
W38-48-48	W39-48-48	3.00	7.00	8.50	2.812	6.000	2.69	3.615	1.190	1 1/8-7	237	1 1/8-7X4.50

# Zero PSI Shipping Plate

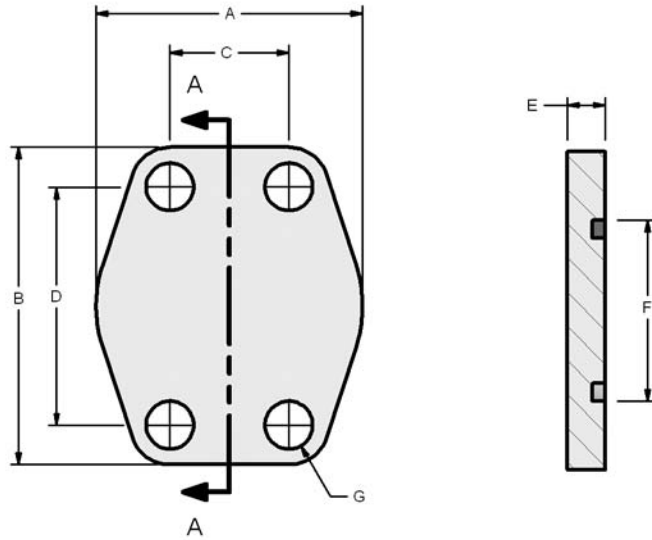
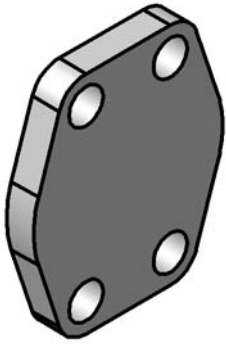

Anchor Fluid Power has developed a low cost solution to leaky, gasketless port covers. Forged steel shipping plates are 0.33" thick, zinc plated for resistance to oxidation, and incorporate an o-ring groove on one side for "Zero Pressure" applications. The opposite side has a machined flat-face for capping off hose ends.

CODE 61 SHIPPING PLATE											
PART NO.	**KIT PART NO.	PAD SIZE	A	B	C	D	E	F	G	MOUNTING HARDWARE	
										O-RING	HHCS
SP-8	SP-8U	.50	1.81	2.12	.688	1.500	.33	1.000	.344	210	5/16-18X.75
SP-12	SP-12U	.75	2.06	2.56	.875	1.875	.33	1.250	.413	214	3/8-16X.75
SP-16	SP-16U	1.00	2.31	2.75	1.031	2.063	.33	1.560	.413	219	3/8-16X.75
SP-20	SP-20U	1.25	2.88	3.12	1.188	2.313	.33	1.750	.469	222	7/16-14X.75
SP-24	SP-24U	1.50	3.25	3.69	1.406	2.750	.33	2.115	.531	225	1/2-13X.75
SP-32	SP-32U	2.00	3.81	4.00	1.688	3.063	.33	2.490	.531	228	1/2-13X.75
SP-40	SP-40U	2.50	4.28	4.50	2.000	3.500	.33	2.995	.531	232	1/2-13X.75
SP-48	SP-48U	3.00	5.16	5.31	2.438	4.188	.33	3.615	.656	237	5/8-11X1.00
SP-56	SP-56U	3.50	5.50	6.00	2.750	4.750	.33	4.095	.656	241	5/8-11X1.00
SP-64	SP-64U	4.00	6.00	6.38	3.062	5.125	.33	4.595	.656	245	5/8-11X1.00

### Applications Include:

- Cylinder Port Covers
- Pump Port Covers
- Stub-Out Header Line Covers
- Maintenance Work
- Great for Painting Protection

CODE 62 SHIPPING PLATE											
PART NO.	**KIT PART NO.	PAD SIZE	A	B	C	D	E	F	G	MOUNTING HARDWARE	
										O-RING	HHCS
SPX-8	SPX-8U	.50	1.94	2.19	.718	1.594	.33	1.000	.354	210	5/16-18X.75
SPX-12	SPX-12U	.75	2.50	2.81	.937	2.000	.33	1.250	.433	214	3/8-16X.75
SPX-16	SPX-16U	1.00	2.75	3.19	1.093	2.250	.33	1.560	.531	219	7/16-14X.75
SPX-20	SPX-20U	1.25	3.06	3.75	1.250	2.625	.33	1.750	.610	222	1/2-13X.75
SPX-24	SPX-24U	1.50	3.75	4.44	1.437	3.125	.33	2.115	.689	225	5/8-11X1.00
SPX-32	SPX-32U	2.00	4.50	5.25	1.750	3.812	.33	2.490	.866	228	3/4-10X1.00

\*\*When ordering this part # you will receive:(1) shipping plate, (4) hex head bolts, and (1) Buna N O-Ring

**NOT FOR USE ON DYNAMIC OR PRESSURIZED APPLICATIONS**

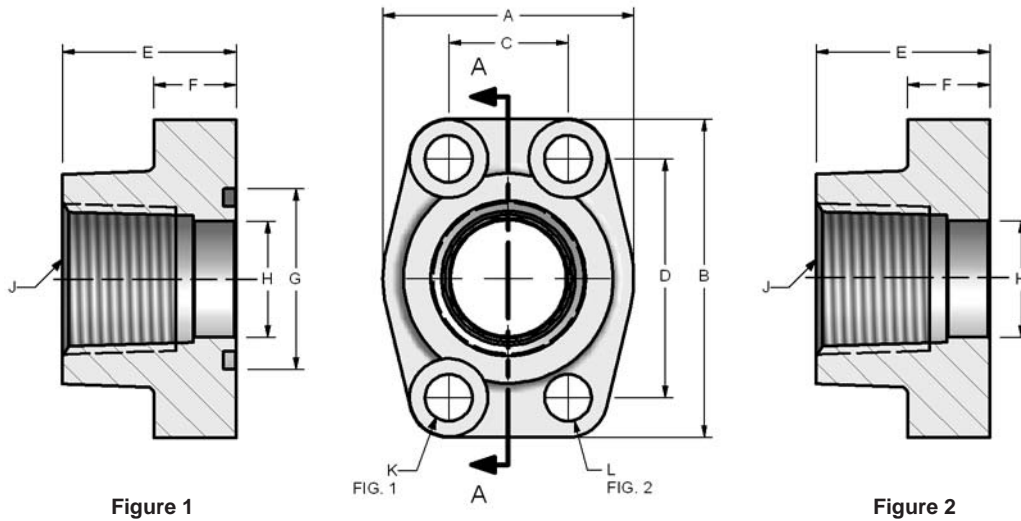

Figure 1

FIG. 1      A      FIG. 2

Figure 2

### CODE 61 NPTF THREAD

PART NO. O-RING FIG. 1	PART NO. FLAT FACE FIG. 2	PORT SIZE	PAD SIZE	A	B	C	D	E	F	G	H	J NPTF	K	L UNC-2B	MOUNTING HARDWARE	
															O-RING	SHCS
W43-8-8	W104-8-8	.50	.50	1.81	2.13	.688	1.500	1.42	.63	1.000	.502	1/2-14	.344	5/16-18	210	5/16-18X1.25
W43-12-12	W104-12-12	.75	.75	1.97	2.56	.875	1.875	1.42	.71	1.250	.752	3/4-14	.406	3/8-16	214	3/8-16X1.50
W43-16-16	W104-16-16	1.00	1.00	2.17	2.75	1.031	2.062	1.50	.71	1.560	1.002	1-11.5	.406	3/8-16	219	3/8-16X1.50
W43-20-20	W104-20-20	1.25	1.25	2.68	3.12	1.188	2.312	1.61	.83	1.750	1.252	1 1/4-11.5	.469	7/16-14	222	7/16-14X1.75
W43-24-24	W104-24-24	1.50	1.50	3.07	3.66	1.406	2.750	1.77	.98	2.115	1.502	1 1/2-11.5	.531	1/2-13	225	1/2-13X1.75
W43-32-32	W104-32-32	2.00	2.00	3.54	4.00	1.688	3.062	1.77	.98	2.490	2.002	2-11.5	.531	1/2-13	228	1/2-13X1.75
W43-40-40	W104-40-40	2.50	2.50	4.09	4.49	2.000	3.500	1.97	.98	2.995	2.502	2 1/2-8	.531	1/2-13	232	1/2-13X1.75
W43-48-48	W104-48-48	3.00	3.00	4.88	5.28	2.438	4.188	1.97	1.06	3.615	3.002	3-8	.656	5/8-11	237	5/8-11X2.00

### CODE 62 NPTF THREAD

PART NO. O-RING FIG. 1	PART NO. FLAT FACE FIG. 2	PORT SIZE	PAD SIZE	A	B	C	D	E	F	G	H	J NPTF	K	L UNC-2B	MOUNTING HARDWARE	
															O-RING	SHCS
W44-8-8	W45-8-8	.50	.50	1.81	2.21	.718	1.594	1.42	.63	1.000	.502	1/2-14	.344	5/8-18	210	5/16-18X1.25
W44-12-12	W45-12-12	.75	.75	2.17	2.80	.937	2.000	1.38	.83	1.250	.752	3/4-14	.406	3/8-16	214	3/8-16X1.50
W44-16-16	W45-16-16	1.00	1.00	2.56	3.19	1.093	2.250	1.65	.98	1.560	1.002	1-11.5	.492	7/16-14	219	7/16-14X1.75
W44-20-20	W45-20-20	1.25	1.25	3.07	3.75	1.250	2.625	1.77	1.06	1.750	1.252	1 1/4-11.5	.531	1/2-13	222	1/2-13X1.75
W44-24-24	W45-24-24	1.50	1.50	3.70	4.41	1.437	3.125	1.97	1.18	2.115	1.502	1 1/2-11.5	.656	5/8-11	225	5/8-11X2.25
W44-32-32	W45-32-32	2.00	2.00	4.50	5.28	1.750	3.812	2.56	1.46	2.490	2.002	2-11.5	.781	3/4-10	228	3/4-10X2.75

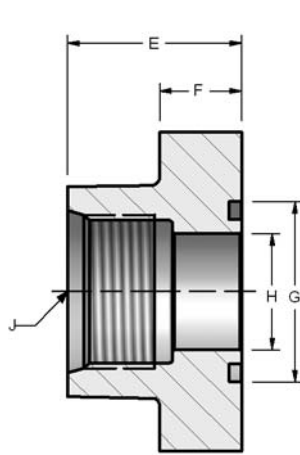
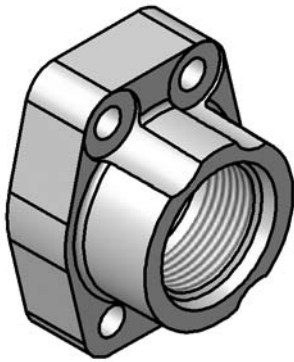

Figure 1

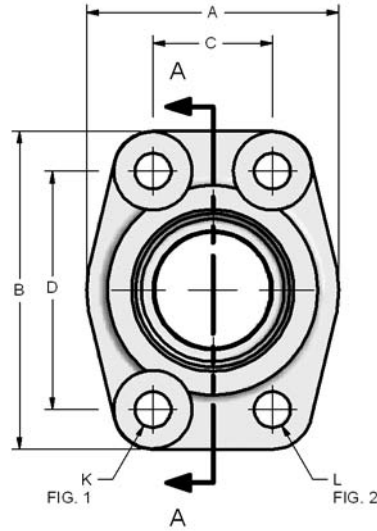

Figure 2

### CODE 61 SAE STRAIGHT THREAD

PART NO. O-RING FIG. 1	PART NO. FLAT FACE FIG. 2	PORT SIZE	PAD SIZE	A	B	C	D	E	F	G	H	J UN/ UNF-2B	K	L UNC-2B	MOUNTING HARDWARE	
															O-RING	SHCS
W46-8-8	W106-8-8	.50	.50	1.81	2.13	.688	1.500	1.42	.63	1.000	.502	3/4-16	.344	5/16-18	210	5/16-18X1.25
W46-12-12	W106-12-12	.75	.75	1.97	2.56	.875	1.875	1.42	.71	1.250	.752	1 1/16-12	.406	3/8-16	214	3/8-16X1.50
W46-16-16	W106-16-16	1.00	1.00	2.17	2.75	1.031	2.062	1.50	.71	1.560	1.002	1 5/16-12	.406	3/8-16	219	3/8-16X1.50
W46-20-20	W106-20-20	1.25	1.25	2.68	3.12	1.188	2.312	1.61	.83	1.750	1.252	1 5/8-12	.469	7/16-14	222	7/16-14X1.75
W46-24-24	W106-24-24	1.50	1.50	3.07	3.66	1.406	2.750	1.77	.98	2.115	1.502	1 7/8-12	.531	1/2-13	225	1/2-13X1.75
*W46-32-32	W106-32-32	2.00	2.00	3.54	4.00	1.688	3.062	1.77	.98	2.490	2.002	2 1/2-12	.531	1/2-13	228	1/2-13X1.75

\*NOTE: 500 PSI max for W46-32-32

### CODE 62 SAE STRAIGHT THREAD

PART NO. O-RING FIG. 1	PART NO. FLAT FACE FIG. 2	PORT SIZE	PAD SIZE	A	B	C	D	E	F	G	H	J UN/ UNF-2B	K	L UNC-2B	MOUNTING HARDWARE	
															O-RING	SHCS
W48-8-8	W49-8-8	.50	.50	1.81	2.21	.718	1.594	1.42	.63	1.000	.502	3/4-16	.344	5/16-18	210	5/16-18X1.25
W48-12-12	W49-12-12	.75	.75	2.17	2.80	.937	2.000	1.38	.83	1.250	.752	1 1/8-12	.406	3/8-16	214	3/8-16X1.50
W48-16-16	W49-16-16	1.00	1.00	2.56	3.19	1.093	2.250	1.65	.98	1.560	1.002	1 5/16-12	.492	7/16-14	219	7/16-14X1.75
W48-20-20	W49-20-20	1.25	1.25	3.07	3.75	1.250	2.625	1.77	1.06	1.750	1.252	1 5/8-12	.531	1/2-13	222	1/2-13X1.75
W48-24-24	W49-24-24	1.50	1.50	3.70	4.41	1.437	3.125	1.97	1.18	2.115	1.502	1 7/8-12	.656	5/8-11	225	5/8-11X2.25
W48-32-32	W49-32-32	2.00	2.00	4.50	5.28	1.750	3.812	2.56	1.46	2.490	2.002	2 1/2-12	.781	3/4-10	228	3/4-10X2.75

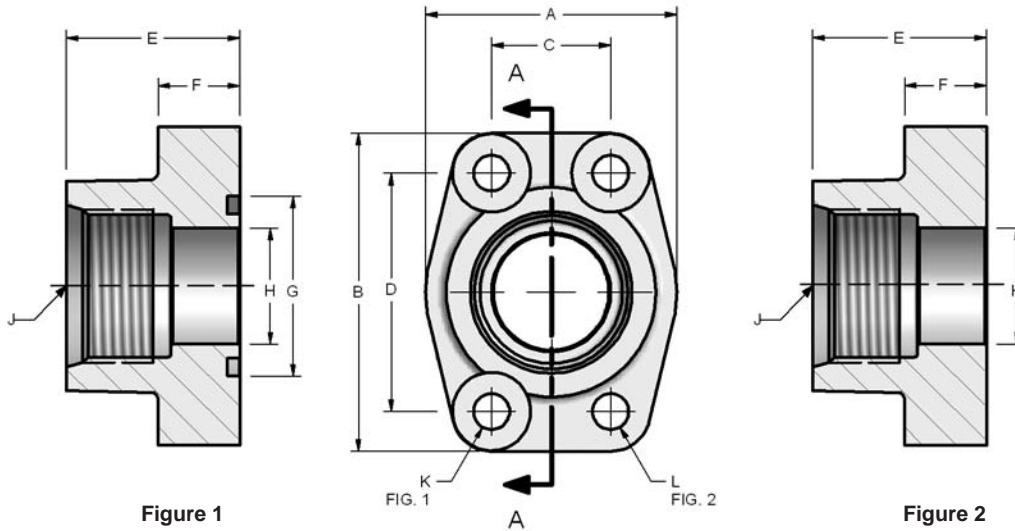

### CODE 61 BSPP THREAD

PART NO. O-RING FIG. 1	PART NO. FLAT FACE FIG. 2	PORT SIZE	PAD SIZE	A	B	C	D	E	F	G	H	J BSPP	K	L UNC-2B	MOUNTING HARDWARE	
															O-RING	SHCS
W192-8-8	W193-8-8	.50	.50	1.81	2.13	.688	1.500	1.42	.63	1.000	.502	.50-14	.344	5/16-18	210	5/16-18X1.25
W192-12-12	W193-12-12	.75	.75	1.97	2.56	.875	1.875	1.42	.71	1.250	.752	.75-14	.406	3/8-16	214	3/8-16X1.50
W192-16-16	W193-16-16	1.00	1.00	2.17	2.75	1.031	2.062	1.50	.71	1.560	1.002	1.00-11	.406	3/8-16	219	3/8-16X1.50
W192-20-20	W193-20-20	1.25	1.25	2.68	3.12	1.188	2.312	1.61	.83	1.750	1.252	1.25-11	.469	7/16-14	222	7/16-14X1.75
W192-24-24	W193-24-24	1.50	1.50	3.07	3.66	1.406	2.750	1.77	.98	2.115	1.502	1.50-11	.531	1/2-13	225	1/2-13X1.75
W192-32-32	W193-32-32	2.00	2.00	3.54	4.00	1.688	3.062	1.77	.98	2.490	2.002	2.00-11	.531	1/2-13	228	1/2-13X1.75

### CODE 62 BSPP THREAD

PART NO. O-RING FIG. 1	PART NO. FLAT FACE FIG. 2	PORT SIZE	PAD SIZE	A	B	C	D	E	F	G	H	J BSPP	K	L UNC-2B	MOUNTING HARDWARE	
															O-RING	SHCS
W194-8-8	W195-8-8	.50	.50	1.81	2.21	.718	1.594	1.42	.63	1.000	.502	.50-14	.344	5/16-18	210	5/16-18X1.25
W194-12-12	W195-12-12	.75	.75	2.17	2.80	.937	2.000	1.38	.83	1.250	.752	.75-14	.406	3/8-16	214	3/8-16X1.50
W194-16-16	W195-16-16	1.00	1.00	2.56	3.19	1.093	2.250	1.65	.98	1.560	1.002	1.00-11	.492	7/16-14	219	7/16-14X1.75
W194-20-20	W195-20-20	1.25	1.25	3.07	3.75	1.250	2.625	1.77	1.06	1.750	1.252	1.25-11	.531	1/2-13	222	1/2-13X1.50
W194-24-24	W195-24-24	1.50	1.50	3.70	4.41	1.437	3.125	1.97	1.18	2.115	1.502	1.50-11	.656	5/8-11	225	5/8-11X2.00
W194-32-32	W195-32-32	2.00	2.00	4.50	5.28	1.750	3.812	2.56	1.46	2.490	2.002	2.00-11	.781	3/4-10	228	3/4-10X2.75

# Male Thread

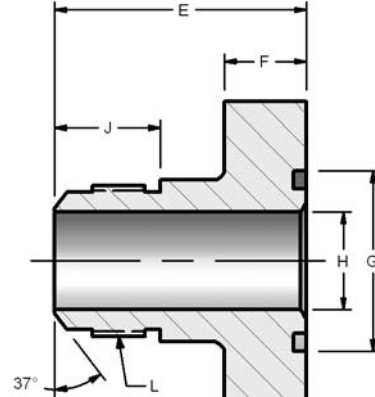
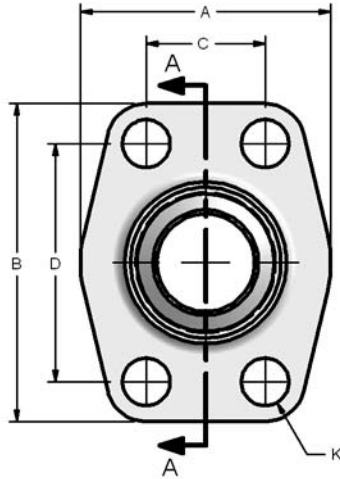
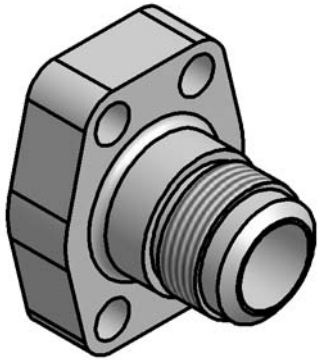

\*NOTE: 4-Bolt Flange hole pattern per SAE J518. Male JIC Thread per SAE J514.

## CODE 61 MALE JIC

PART NO.	PAD SIZE	A	B	C	D	E	F	G	H	J	K	L UN/UNF-2A	MOUNTING HARDWARE	
													O-RING	SHCS
W300-8-8	.50	1.81	2.13	.688	1.500	1.75	.630	1.000	.394	.657	.344	3/4-16	210	5/16-18X1.25
W300-12-12	.75	1.97	2.56	.875	1.875	2.12	.710	1.250	.611	.864	.413	1 1/16-12	214	3/8-16X1.50
W300-16-16	1.00	2.17	2.75	1.031	2.062	2.18	.710	1.560	.844	.911	.413	1 5/16-12	219	3/8-16X1.50
W300-20-20	1.25	2.68	3.12	1.188	2.312	2.44	.830	1.750	1.078	.958	.469	1 5/8-12	222	7/16-14X1.75
W300-24-24	1.50	3.07	3.66	1.406	2.750	2.81	.980	2.115	1.318	1.083	.531	1 7/8-12	225	1/2-13X1.75
W300-32-32	2.00	3.54	4.00	1.688	3.062	3.25	.980	2.490	1.781	1.333	.531	2 1/2-12	228	1/2-13X1.75

## CODE 62 MALE JIC

PART NO.	PAD SIZE	A	B	C	D	E	F	G	H	J	K	L UN/UNF-2A	MOUNTING HARDWARE	
													O-RING	SHCS
W600-8-8	.50	1.81	2.21	.719	1.594	1.75	.630	1.000	.394	.657	.344	3/4-16	210	5/16-18X1.25
W600-12-12	.75	2.17	2.80	.937	2.000	2.31	.830	1.250	.611	.864	.413	1-1/16-12	214	3/8-16X1.50
W600-16-16	1.00	2.56	3.19	1.093	2.250	2.62	.980	1.560	.844	.911	.492	1-5/16-12	219	7/16-14X1.75
W600-20-20	1.25	3.07	3.75	1.250	2.625	2.81	1.060	1.750	1.078	.958	.531	1-5/8-12	222	1/2-13X1.75
W600-24-24	1.50	3.70	4.41	1.437	3.125	3.25	1.180	2.115	1.318	1.083	.656	1-7/8-12	225	5/8-11X2.25
W600-32-32	2.00	4.50	5.28	1.750	3.812	3.91	1.460	2.490	1.781	1.333	.781	2 1/2-12	228	3/4-10X2.75

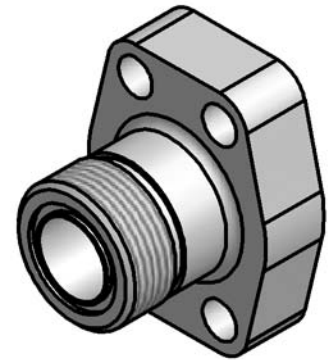
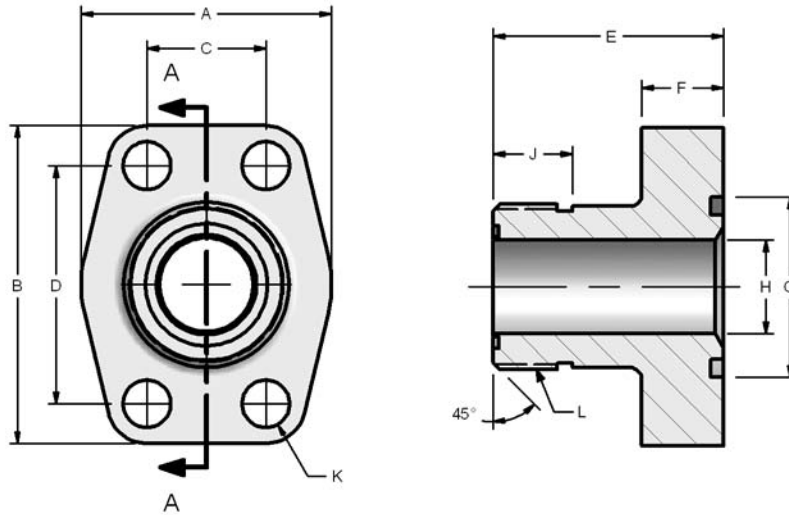

CODE 61 MALE ORFS														
PART NO.	PAD SIZE	A	B	C	D	E	F	G	H	J	K	L UN-2A	MOUNTING HARDWARE	
													O-RING	SHCS
W304-8-8	.50	1.81	2.13	.688	1.500	1.75	.630	1.000	.394	.504	.344	13/16-16	210	5/16-18X1.25
W304-12-12	.75	1.97	2.56	.875	1.875	2.00	.710	1.250	.611	.670	.413	1 3/16-12	214	3/8-16X1.50
W304-16-16	1.00	2.17	2.75	1.031	2.062	2.00	.710	1.560	.811	.689	.413	1 7/16-12	219	3/8-16X1.50
W304-20-20	1.25	2.68	3.12	1.188	2.312	2.25	.830	1.750	1.024	.689	.469	1 11/16-12	222	7/16-14X1.75
W304-24-24	1.50	3.07	3.66	1.406	2.750	2.50	.980	2.115	1.260	.689	.531	2-12	225	1/2-13X2.00

CODE 62 MALE ORFS														
PART NO.	PAD SIZE	A	B	C	D	E	F	G	H	J	K	L UN-2A	MOUNTING HARDWARE	
													O-RING	SHCS
W604-8-8	.50	1.81	2.21	.719	1.594	1.75	.630	1.000	.394	.504	.344	13/16-16	210	5/16-18X1.25
W604-12-12	.75	2.17	2.80	.937	2.000	2.25	.830	1.250	.611	.670	.413	1 3/16-12	214	3/8-16X1.50
W604-16-16	1.00	2.56	3.19	1.093	2.250	2.50	.980	1.560	.811	.689	.492	1 7/16-12	219	7/16-14X1.75
W604-20-20	1.25	3.07	3.75	1.250	2.625	2.62	1.060	1.750	1.024	.689	.531	1 11/16-12	222	1/2-13X1.75
W604-24-24	1.50	3.70	4.41	1.437	3.125	2.88	1.180	2.115	1.260	.689	.656	2-12	225	5/8-11X2.25

# Flat Socket Weld Pipe

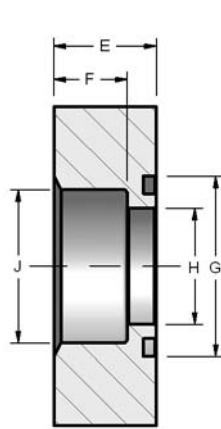
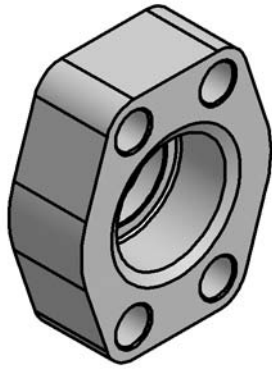

Figure 1

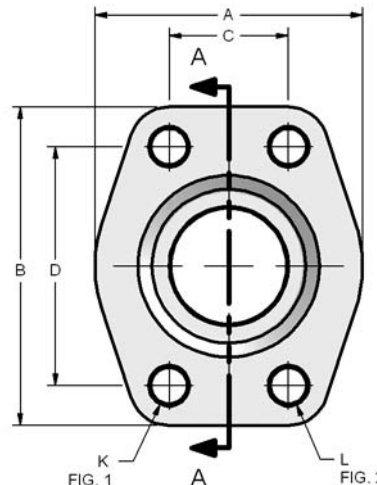

FIG. 1 A FIG. 2

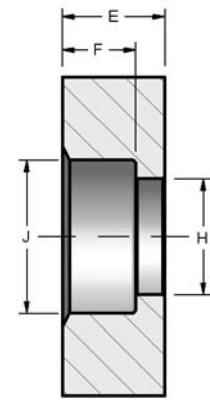

Figure 2

## CODE 61 FLAT SOCKET WELD - PIPE

PART NO. O-RING FIG. 1.	PART NO. FLAT FACE FIG. 2	PIPE SIZE	PAD SIZE	A	B	C	D	E	F	G	H	J	K	L UNC-2B	MOUNTING HARDWARE	
															O-RING	SHCS
W4-8-8	W61-8-8	.50	.50	1.813	2.125	.688	1.500	.750	.560	1.000	.502	.855	.344	5/16-18	210	5/16-18X1.50
W4-12-12	W61-12-12	.75	.75	2.063	2.563	.875	1.875	.750	.560	1.250	.752	1.062	.406	3/8-16	214	3/8-16X1.75
W4-16-16	W61-16-16	1.00	1.00	2.313	2.75	1.031	2.063	.880	.630	1.560	1.002	1.328	.406	3/8-16	219	3/8-16X1.75
W4-20-20	W61-20-20	1.25	1.25	2.875	3.125	1.188	2.313	.940	.690	1.750	1.252	1.672	.469	7/16-14	222	7/16-14X1.75
W4-24-24	W61-24-24	1.50	1.50	3.25	3.688	1.406	2.75	1.190	.750	2.115	1.502	1.922	.531	1/2-13	225	1/2-13X2.25
W4-32-32	W61-32-32	2.00	2.00	3.813	4.00	1.688	3.063	1.380	.875	2.490	2.002	2.406	.531	1/2-13	228	1/2-13X2.50
W4-40-40	W61-40-40	2.50	2.50	4.281	4.50	2.000	3.500	1.750	1.00	2.995	2.502	2.906	.531	1/2-13	232	1/2-13X2.75
W4-48-48	W61-48-48	3.00	3.00	5.156	5.313	2.438	4.188	2.120	1.250	3.615	3.002	3.547	.656	5/8-11	237	5/8-11X3.50

## CODE 62 FLAT SOCKET WELD - PIPE

PART NO. O-RING FIG. 1	PART NO. FLAT FACE FIG. 2	PIPE SIZE	PAD SIZE	A	B	C	D	E	F	G	H	J	K	L UNC-2B	MOUNTING HARDWARE	
															O-RING	SHCS
W59-8-8	W60-8-8	.50	.50	1.94	2.30	.718	1.594	1.25	.560	1.000	.502	.855	.344	5/16-18	210	5/16-18X2.00
W59-12-12	W60-12-12	.75	.75	2.50	2.95	.937	2.000	1.250	.560	1.250	.752	1.062	.406	3/8-16	214	3/8-16X2.00
W59-16-16	W60-16-16	1.00	1.00	2.75	3.19	1.093	2.250	1.500	.630	1.560	1.002	1.328	.492	7/16-14	219	7/16-14X2.50
W59-20-20	W60-20-20	1.25	1.25	3.06	3.75	1.250	2.625	1.500	.690	1.750	1.252	1.672	.531	1/2-13	222	1/2-13X2.50
W59-24-24	W60-24-24	1.50	1.50	3.75	4.44	1.437	3.125	1.750	.750	2.115	1.502	1.922	.656	5/8-11	225	5/8-11X3.00
W59-32-32	W60-32-32	2.00	2.00	4.50	5.25	1.750	3.812	1.750	.875	2.490	2.002	2.406	.781	3/4-10	228	3/4-10X3.00
*W59-40-40	*W60-40-40	2.50	2.50	5.87	6.87	2.312	4.875	2.060	1.000	2.995	2.502	2.906	.906	7/8-9	232	**7/8-9X3.50
*W59-48-48	*W60-48-48	3.00	3.00	7.00	8.50	2.812	6.000	2.620	1.250	3.615	3.002	3.547	1.190	1-1/8-7	237	**1 1/8-7X4.50

\*3000 PSI Max Working Pressure

\*\*HHCS

## CODE 61 FLAT SOCKET WELD - PIPE

PART NO. O-RING FIG. 1	PART NO. FLAT FACE FIG. 2	PIPE SIZE	PAD SIZE	A	B	C	D	E	F	G	H	J	K	L UNC-2B	MOUNTING HARDWARE	
															O-RING	SHCS
*W72-48-48	*W91-48-48	3.00	3.00	5.12	5.31	2.438	4.188	1.380	1.120	3.615	3.002	3.547	.656	5/8-11	237	5/8-11X2.50
W72-56-56	W91-56-56	3.50	3.50	5.50	6.00	2.750	4.750	1.440	1.190	4.095	3.502	4.047	.656	5/8-11	241	5/8-11X2.75
W72-64-64	W91-64-64	4.00	4.00	6.00	6.38	3.062	5.125	1.500	1.250	4.595	4.002	4.578	.656	5/8-11	245	5/8-11X2.75
W72-80-80	W91-80-80	5.00	5.00	7.12	7.25	3.625	6.000	1.750	1.380	5.595	5.002	5.641	.656	5/8-11	253	5/8-11X3.00

\*NOTE: 500 PSI max for W72-48-48 & W91-48-48

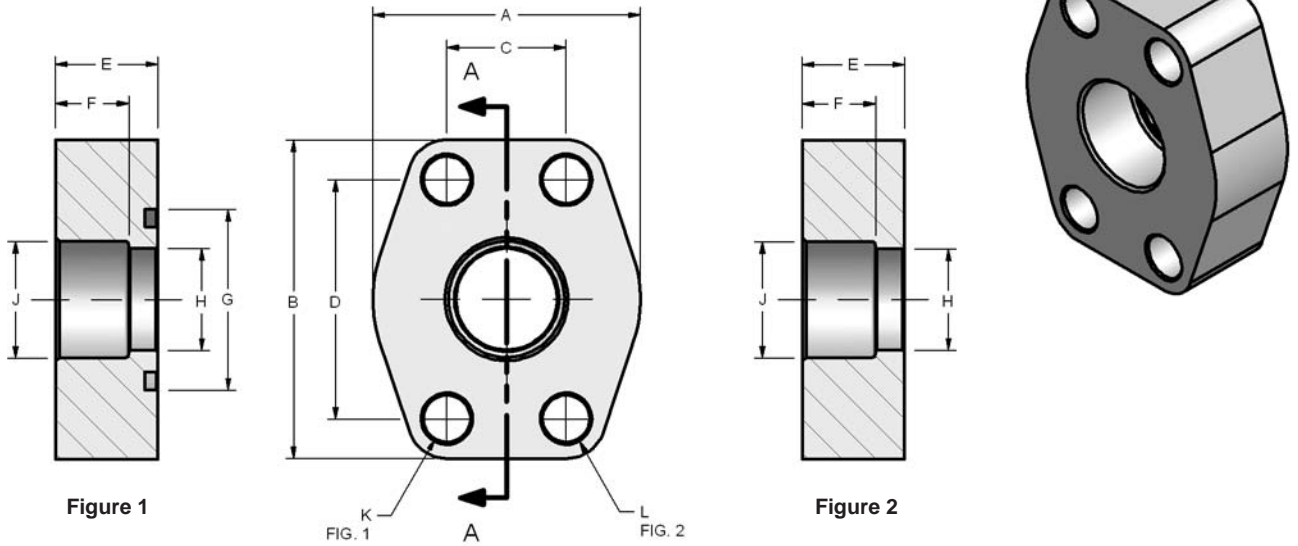

CODE 61 FLAT SOCKET WELD - TUBE																
PART NO. O-RING FIG. 1	PART NO. FLAT FACE FIG. 2	TUBE SIZE	PAD SIZE	A	B	C	D	E	F	G	H	J	K	L UNC-2B	MOUNTING HARDWARE	
															O-RING	SHCS
W6-12-12	W62-12-12	.75	.75	2.060	2.560	.875	1.875	.750	.560	1.250	.625	.752	.406	3/8-16	214	3/8-16X1.50
W6-16-12	W62-16-12	1.00	.75	2.060	2.560	.875	1.875	.750	.560	1.250	.750	1.002	.406	3/8-16	214	3/8-16X1.50
W6-16-16	W62-16-16	1.00	1.00	2.310	2.750	1.031	2.062	.880	.630	1.560	.875	1.002	.406	3/8-16	219	3/8-16X1.75
W6-20-16	W62-20-16	1.25	1.00	2.310	2.750	1.031	2.062	.880	.630	1.560	1.000	1.252	.406	3/8-16	219	3/8-16X1.75
W6-20-20	W62-20-20	1.25	1.25	2.880	3.120	1.188	2.312	.940	.690	1.750	1.125	1.252	.469	7/16-14	222	7/16-14X1.75
W6-24-20	W62-24-20	1.50	1.25	2.880	3.120	1.188	2.312	.940	.690	1.750	1.250	1.502	.469	7/16-14	222	7/16-14X1.75
W6-24-24	W62-24-24	1.50	1.50	3.250	3.690	1.406	2.750	1.190	.750	2.115	1.375	1.502	.531	1/2-13	225	1/2-13X2.25
W6-28-24	W62-28-24	1.75	1.50	3.250	3.690	1.406	2.750	1.190	.750	2.115	1.500	1.752	.531	1/2-13	225	1/2-13X2.25
W6-32-32	W62-32-32	2.00	2.00	3.810	4.000	1.688	3.062	1.380	.875	2.490	1.875	2.002	.531	1/2-13	228	1/2-13X2.50
W6-36-32	W62-36-32	2.25	2.00	3.810	4.000	1.688	3.062	1.380	.875	2.490	2.000	2.252	.531	1/2-13	228	1/2-13X2.50

CODE 62 FLAT SOCKET WELD - TUBE																
PART NO. O-RING FIG. 1	PART NO. FLAT FACE FIG. 2	TUBE SIZE	PAD SIZE	A	B	C	D	E	F	G	H	J	K	L UNC-2B	MOUNTING HARDWARE	
															O-RING	SHCS
W58-12-12	W63-12-12	.75	.75	2.50	2.95	.937	2.000	1.250	.560	1.250	.625	.752	.406	3/8-16	214	3/8-16X2.00
W58-16-12	W63-16-12	1.00	.75	2.50	2.95	.937	2.000	1.250	.560	1.250	.750	1.002	.406	3/8-16	214	3/8-16X2.00
W58-16-16	W63-16-16	1.00	1.00	2.75	3.19	1.093	2.250	1.500	.630	1.560	.875	1.002	.492	7/16-14	219	7/16-14X2.50
W58-20-16	W63-20-16	1.25	1.00	2.75	3.19	1.093	2.250	1.500	.630	1.560	1.000	1.252	.492	7/16-14	219	7/16-14X2.50
W58-20-20	W63-20-20	1.25	1.25	3.06	3.75	1.250	2.625	1.500	.690	1.750	1.125	1.252	.531	1/2-13	222	1/2-13X2.50
W58-24-20	W63-24-20	1.50	1.25	3.06	3.75	1.250	2.625	1.500	.690	1.750	1.250	1.502	.531	1/2-13	222	1/2-13X2.50
W58-24-24	W63-24-24	1.50	1.50	3.75	4.44	1.437	3.125	1.750	.750	2.115	1.375	1.502	.656	5/8-11	225	5/8-11X3.00
W58-28-24	W63-28-24	1.75	1.50	3.75	4.44	1.437	3.125	1.750	.750	2.115	1.500	1.752	.656	5/8-11	225	5/8-11X3.00
W58-32-32	W63-32-32	2.00	2.00	4.50	5.25	1.750	3.812	1.750	.875	2.490	1.875	2.002	.781	3/4-10	228	3/4-10X3.00
W58-36-32	W63-36-32	2.25	2.00	4.50	5.25	1.750	3.812	1.750	.875	2.490	2.000	2.252	.781	3/4-10	228	3/4-10X3.00

# Deep Socket Weld Pipe

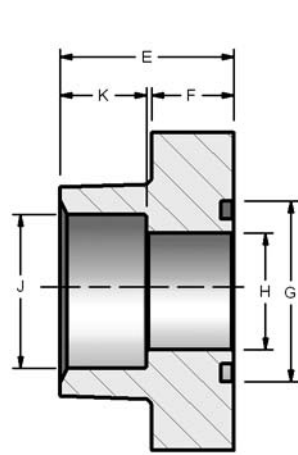
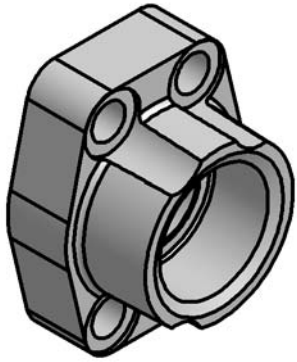

Figure 1

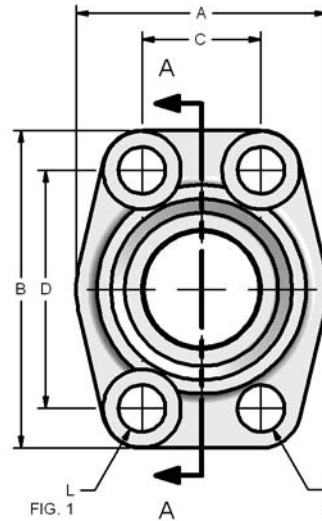

FIG. 1 A FIG. 2

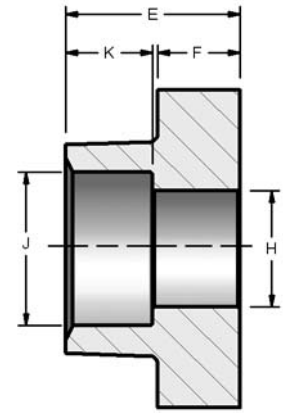

Figure 2

## CODE 61 DEEP SOCKET WELD - PIPE

PART NO. O-RING FIG. 1	PART NO. FLAT FACE FIG. 2	PIPE SIZE	PAD SIZE	A	B	C	D	E	F	G	H	J	K	L	M UNC-2B	MOUNTING HARDWARE	
																O-RING	SHCS
W31-8-8	W3-8-8	.50	.50	1.81	2.13	.688	1.500	1.42	.63	1.000	.502	.855	.75	.344	5/16-18	210	5/16-18X1.25
W31-12-12	W3-12-12	.75	.75	1.97	2.56	.875	1.875	1.42	.71	1.250	.752	1.062	.75	.406	3/8-16	214	3/8-16X1.50
W31-16-16	W3-16-16	1.00	1.00	2.17	2.75	1.031	2.062	1.50	.71	1.560	1.002	1.328	.75	.406	3/8-16	219	3/8-16X1.50
W31-20-20	W3-20-20	1.25	1.25	2.68	3.12	1.188	2.312	1.61	.83	1.750	1.252	1.672	.87	.469	7/16-14	222	7/16-14X1.75
W31-24-24	W3-24-24	1.50	1.50	3.07	3.66	1.406	2.750	1.77	.98	2.115	1.502	1.922	.94	.531	1/2-13	225	1/2-13X1.75
W31-32-32	W3-32-32	2.00	2.00	3.54	4.00	1.688	3.062	1.77	.98	2.490	2.002	2.406	1.02	.531	1/2-13	228	1/2-13X1.75
W31-40-40	W3-40-40	2.50	2.50	4.09	4.49	2.000	3.500	1.97	.98	2.995	2.502	2.908	1.18	.531	1/2-13	232	1/2-13X1.75
W31-48-48	W3-48-48	3.00	3.00	4.88	5.28	2.438	4.188	1.97	1.06	3.615	3.002	3.547	1.34	.656	5/8-11	237	5/8-11X2.00

## CODE 62 DEEP SOCKET WELD - PIPE

PART NO. O-RING FIG. 1	PART NO. FLAT FACE FIG. 2	PIPE SIZE	PAD SIZE	A	B	C	D	E	F	G	H	J	K	L	M UNC-2B	MOUNTING HARDWARE	
																O-RING	SHCS
W81-8-8	W80-8-8	.50	.50	1.81	2.21	.718	1.594	1.42	.63	1.000	.502	.855	.75	.344	5/16-18	210	5/16-18X1.25
W81-12-12	W80-12-12	.75	.75	2.17	2.80	.937	2.000	1.38	.83	1.250	.752	1.062	.87	.406	3/8-16	214	3/8-16X1.50
W81-16-16	W80-16-16	1.00	1.00	2.56	3.19	1.093	2.250	1.65	.98	1.560	1.002	1.328	.87	.492	7/16-14	219	7/16-14X1.75
W81-20-20	W80-20-20	1.25	1.25	3.07	3.75	1.250	2.625	1.77	1.06	1.750	1.252	1.672	.98	.531	1/2-13	222	1/2-13X1.75
W81-24-24	W80-24-24	1.50	1.50	3.70	4.41	1.437	3.125	1.97	1.18	2.115	1.502	1.922	1.10	.656	5/8-11	225	5/8-11X2.25
W81-32-32	W80-32-32	2.00	2.00	4.50	5.28	1.750	3.812	2.56	1.46	2.490	2.002	2.406	.94	.781	3/4-10	228	3/4-10X2.75

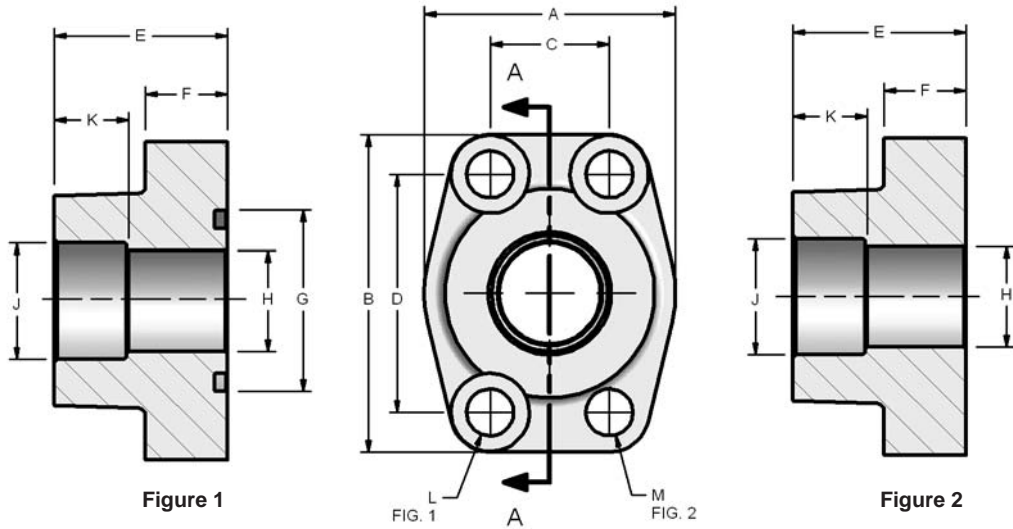

### CODE 61 DEEP SOCKET WELD - TUBE

PART NO. O-RING FIG. 1	PART NO. FLAT FACE FIG. 2	TUBE SIZE	PAD SIZE	A	B	C	D	E	F	G	H	J	K	L	M UNC-2B	MOUNTING HARDWARE	
																O-RING	SHCS
W51-12-12	W5-12-12	.75	.75	1.97	2.56	.875	1.875	1.42	.71	1.250	.625	.752	.560	.406	3/8-16	214	3/8-16X1.50
W51-16-12	W5-16-12	1.00	.75	1.97	2.56	.875	1.875	1.42	.71	1.250	.750	1.002	.560	.406	3/8-16	214	3/8-16X1.50
W51-16-16	W5-16-16	1.00	1.00	2.17	2.75	1.031	2.062	1.50	.71	1.560	.875	1.002	.630	.406	3/8-16	219	3/8-16X1.50
W51-20-16	W5-20-16	1.25	1.00	2.17	2.75	1.031	2.062	1.50	.71	1.560	1.000	1.252	.630	.406	3/8-16	219	3/8-16X1.50
W51-20-20	W5-20-20	1.25	1.25	2.68	3.12	1.188	2.312	1.61	.83	1.750	1.125	1.252	.690	.469	7/16-14	222	7/16-14X1.75
W51-24-20	W5-24-20	1.50	1.25	2.68	3.12	1.188	2.312	1.61	.83	1.750	1.250	1.502	.690	.469	7/16-14	222	7/16-14X1.75
W51-24-24	W5-24-24	1.50	1.50	3.07	3.66	1.406	2.750	1.77	.98	2.115	1.375	1.502	.750	.531	1/2-13	225	1/2-13X1.75
W51-28-24	W5-28-24	1.75	1.50	3.07	3.66	1.406	2.750	1.77	.98	2.115	1.500	1.752	.750	.531	1/2-13	225	1/2-13X1.75
W51-32-32	W5-32-32	2.00	2.00	3.54	4.00	1.688	3.062	1.77	.98	2.490	1.875	2.002	.870	.531	1/2-13	228	1/2-13X1.75
W51-36-32	W5-36-32	2.25	2.00	3.54	4.00	1.688	3.062	1.77	.98	2.490	2.000	2.252	.870	.531	1/2-13	228	1/2-13X1.75
W51-40-40	W5-40-40	2.50	2.50	4.09	4.49	2.000	3.500	1.97	.98	2.995	2.375	2.502	1.000	.531	1/2-13	232	1/2-13X1.75
W51-44-40	W5-44-40	2.75	2.50	4.09	4.49	2.000	3.500	1.97	.98	2.995	2.500	2.752	1.000	.531	1/2-13	232	1/2-13X1.75

### CODE 62 DEEP SOCKET WELD - TUBE

PART NO. O-RING FIG. 1	PART NO. FLAT FACE FIG. 2	TUBE SIZE	PAD SIZE	A	B	C	D	E	F	G	H	J	K	L	M UNC-2B	MOUNTING HARDWARE	
																O-RING	SHCS
W83-12-12	W82-12-12	.75	.75	2.17	2.80	.937	2.000	1.38	.83	1.250	.752	.752	.560	.406	3/8-16	214	3/8-16X1.50
W83-16-12	W82-16-12	1.00	.75	2.17	2.80	.937	2.000	1.38	.83	1.250	.752	1.002	.560	.406	3/8-16	214	3/8-16X1.50
W83-16-16	W82-16-16	1.00	1.00	2.56	3.19	1.093	2.250	1.65	.98	1.560	1.002	1.002	.630	.492	7/16-14	219	7/16-14X1.75
W83-20-16	W82-20-16	1.25	1.00	2.56	3.19	1.093	2.250	1.65	.98	1.560	1.002	1.252	.630	.492	7/16-14	219	7/16-14X1.75
W83-20-20	W82-20-20	1.25	1.25	3.07	3.75	1.250	2.625	1.77	1.06	1.750	1.252	1.252	.690	.531	1/2-13	222	1/2-13X1.75
W83-24-20	W82-24-20	1.50	1.25	3.07	3.75	1.250	2.625	1.77	1.06	1.750	1.252	1.502	.690	.531	1/2-13	222	1/2-13X1.75
W83-24-24	W82-24-24	1.50	1.50	3.70	4.41	1.437	3.125	1.97	1.18	2.115	1.502	1.502	.750	.656	5/8-11	225	5/8-11X2.25
W83-28-24	W82-28-24	1.75	1.50	3.70	4.41	1.437	3.125	1.97	1.18	2.115	1.502	1.750	.750	.656	5/8-11	225	5/8-11X2.25
W83-32-32	W82-32-32	2.00	2.00	4.50	5.28	1.750	3.812	2.56	1.46	2.490	2.002	2.002	.870	.781	3/4-10	228	3/4-10X2.75
W83-36-32	W82-36-32	2.25	2.00	4.50	5.28	1.750	3.812	2.56	1.46	2.490	2.002	2.252	.870	.781	3/4-10	228	3/4-10X2.75

# Butt Weld Pipe

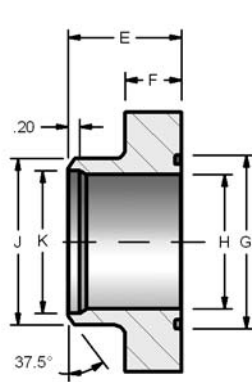
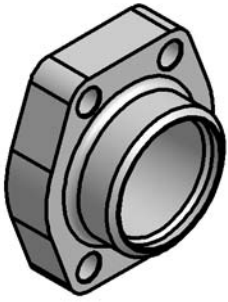

Figure 1

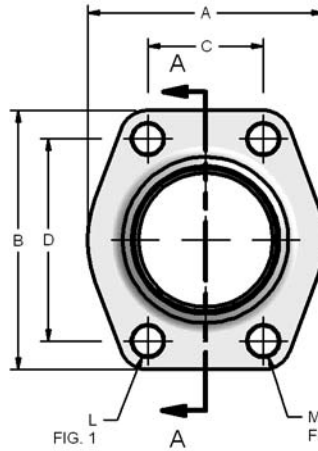

FIG. 1 A FIG. 2

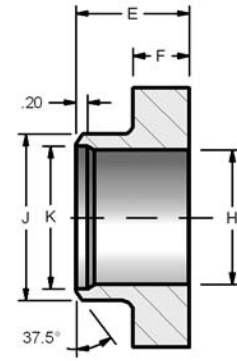

Figure 2

## CODE 61 BUTT WELD - SCHEDULE 40 PIPE

PART NO. O-RING FIG. 1	PART NO. FLAT FACE FIG. 2	PIPE SIZE	PAD SIZE	A	B	C	D	E	F	G	H	J	K	L	M UNC-2B	MOUNTING HARDWARE	
																O-RING	SHCS
W35-8	W34-8	.50	.50	1.81	2.13	.688	1.500	1.42	.63	1.000	.548	.840	.624	.344	5/16-18	210	5/16-18X1.25
W35-12	W34-12	.75	.75	1.97	2.56	.875	1.875	1.42	.71	1.250	.744	1.050	.846	.406	3/8-16	214	3/8-16X1.50
W35-16	W34-16	1.00	1.00	2.17	2.75	1.031	2.062	1.50	.71	1.560	.959	1.315	1.051	.406	3/8-16	219	3/8-16X1.50
W35-20	W34-20	1.25	1.25	2.68	3.12	1.188	2.312	1.61	.83	1.750	1.280	1.660	1.382	.469	7/16-14	222	7/16-14X1.75
W35-24	W34-24	1.50	1.50	3.07	3.66	1.406	2.750	1.73	.98	2.115	1.502	1.900	1.612	.531	1/2-13	225	1/2-13X1.75
W35-32	W34-32	2.00	2.00	3.54	4.00	1.688	3.062	1.77	.98	2.490	1.941	2.375	2.069	.531	1/2-13	228	1/2-13X1.75
W35-40	W34-40	2.50	2.50	4.09	4.49	2.000	3.500	1.97	.98	2.995	2.325	2.875	2.471	.531	1/2-13	232	1/2-13X1.75
W35-48	W34-48	3.00	3.00	4.88	5.28	2.438	4.188	1.97	1.06	3.615	2.902	3.500	3.070	.656	5/8-11	237	5/8-11X2.00

## CODE 61 BUTT WELD - SCHEDULE 80 PIPE

PART NO. O-RING FIG. 1	PART NO. FLAT FACE FIG. 2	PIPE SIZE	PAD SIZE	A	B	C	D	E	F	G	H	J	K	L	M UNC-2B	MOUNTING HARDWARE	
																O-RING	SHCS
W24-8	W23-8	.50	.50	1.81	2.13	.688	1.500	1.42	.63	1.000	.548	.840	SCHEDULE 40 ONLY	.344	5/16-18	210	5/16-18X1.25
W24-12	W23-12	.75	.75	1.97	2.56	.875	1.875	1.42	.71	1.250	.744	1.050		.406	3/8-16	214	3/8-16X1.50
W24-16	W23-16	1.00	1.00	2.17	2.75	1.031	2.062	1.50	.71	1.560	.959	1.315		.406	3/8-16	219	3/8-16X1.50
W24-20	W23-20	1.25	1.25	2.68	3.12	1.188	2.312	1.61	.83	1.750	1.280	1.660		.469	7/16-14	222	7/16-14X1.75
W24-24	W23-24	1.50	1.50	3.07	3.66	1.406	2.750	1.73	.98	2.115	1.502	1.900		.531	1/2-13	225	1/2-13X1.75
W24-32	W23-32	2.00	2.00	3.54	4.00	1.688	3.062	1.77	.98	2.490	1.941	2.375		.531	1/2-13	228	1/2-13X1.75
W24-40	W23-40	2.50	2.50	4.09	4.49	2.000	3.500	1.97	.98	2.995	2.325	2.875		.531	1/2-13	232	1/2-13X1.75
W24-48	W23-48	3.00	3.00	4.88	5.28	2.438	4.188	1.97	1.06	3.615	2.902	3.500		.656	5/8-11	237	5/8-11X2.00

## CODE 61 BUTT WELD - SCHEDULE 160 PIPE

PART NO. O-RING FIG. 1	PART NO. FLAT FACE FIG. 2	PIPE SIZE	PAD SIZE	A	B	C	D	E	F	G	H	J	K	L	M UNC-2B	MOUNTING HARDWARE	
																O-RING	SHCS
W27-8	W25-8	.50	.50	1.81	2.13	.688	1.500	1.42	.63	1.000	.466	.840	SCHEDULE 40 ONLY	.344	5/16-18	210	5/16-18X1.25
W27-12	W25-12	.75	.75	1.97	2.56	.875	1.875	1.42	.71	1.250	.614	1.050		.406	3/8-16	214	3/8-16X1.50
W27-16	W25-16	1.00	1.00	2.17	2.75	1.031	2.062	1.50	.71	1.560	.817	1.315		.406	3/8-16	219	3/8-16X1.50
W27-20	W25-20	1.25	1.25	2.68	3.12	1.188	2.132	1.61	.83	1.750	1.162	1.660		.469	7/16-14	222	7/16-14X1.75
W27-24	W25-24	1.50	1.50	3.07	3.66	1.406	2.750	1.73	.98	2.115	1.340	1.900		.531	1/2-13	225	1/2-13X1.75
W27-32	W25-32	2.00	2.00	3.54	4.00	1.688	3.062	1.77	.98	2.490	1.689	2.375		.531	1/2-13	228	1/2-13X1.75
W27-40	W25-40	2.50	2.50	4.09	4.49	2.000	3.500	1.97	.98	2.995	2.127	2.875		.531	1/2-13	232	1/2-13X1.75
W27-48	W25-48	3.00	3.00	4.88	5.28	2.438	4.188	1.97	1.06	3.615	2.626	3.500		.656	5/8-11	237	5/8-11X2.00

\*NOTE: Also available in sizes 3 1/2", 4", and 5". Consult factory for specifications.

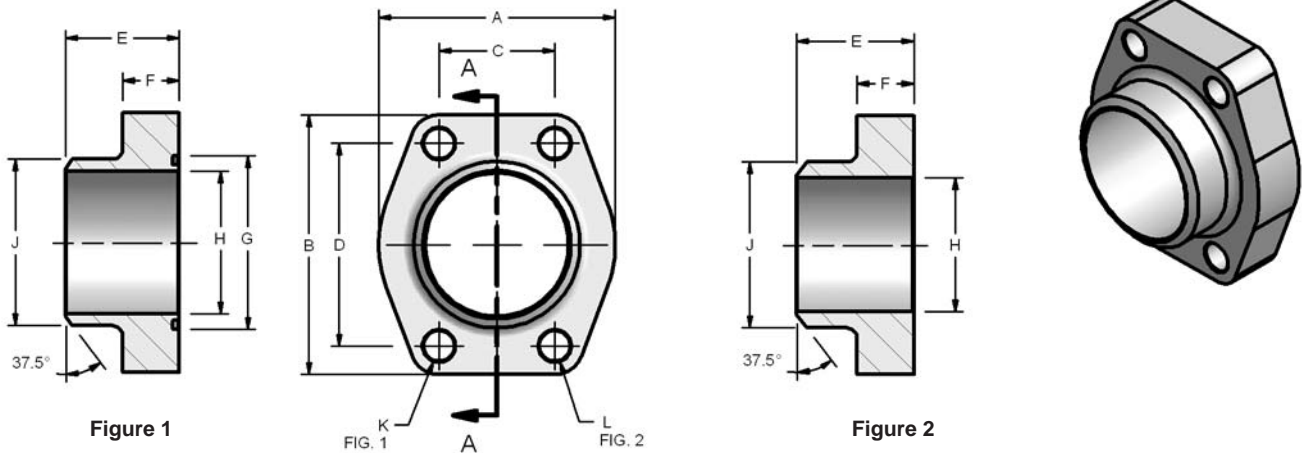

Figure 1

FIG. 1 A L FIG. 2

Figure 2

### CODE 62 BUTT WELD - SCHEDULE 80 PIPE

PART NO. O-RING FIG. 1	PART NO. FLAT FACE FIG. 2	PIPE SIZE	PAD SIZE	A	B	C	D	E	F	G	H	J	K	L UNC-2B	MOUNTING HARDWARE	
															O-RING	SHCS
W28-8	W26-8	.50	.50	1.81	2.21	.718	1.594	1.42	.63	1.000	.548	.840	.344	5/16-18	210	5/16-18X1.25
W28-12	W26-12	.75	.75	2.17	2.80	.937	2.000	1.38	.83	1.250	.744	1.050	.406	3/8-16	214	3/8-16X1.50
W28-16	W26-16	1.00	1.00	2.56	3.19	1.093	2.250	1.61	.83	1.560	.959	1.315	.492	7/16-14	219	7/16-14X1.75
W28-20	W26-20	1.25	1.25	3.07	3.75	1.250	2.625	1.73	.98	1.750	1.280	1.660	.531	1/2-13	222	1/2-13X1.75
W28-24	W26-24	1.50	1.50	3.70	4.41	1.437	3.125	2.17	1.18	2.115	1.502	1.900	.656	5/8-11	225	5/8-11X2.25
W28-32	W26-32	2.00	2.00	4.50	5.28	1.750	3.812	2.56	1.46	2.490	1.941	2.375	.781	3/4-10	228	3/4-10X3.00
*W28-40	*W26-40	2.50	2.50	5.00	6.88	2.312	4.875	2.37	1.50	2.995	2.325	2.875	.940	7/8-9	232	7/8-9X3.00
*W28-48	*W26-48	3.00	3.00	6.00	8.50	2.812	6.000	2.96	2.00	3.615	2.902	3.500	1.190	1 1/8-7	237	1 1/8-7X4.00

### CODE 62 BUTT WELD - SCHEDULE 160 PIPE

PART NO. O-RING FIG. 1	PART NO. FLAT FACE FIG. 2	PIPE SIZE	PAD SIZE	A	B	C	D	E	F	G	H	J	K	L UNC-2B	MOUNTING HARDWARE	
															O-RING	SHCS
W30-8	W29-8	.50	.50	1.81	2.21	.718	1.594	1.42	.63	1.000	.466	.840	.344	5/16-18	210	5/16-18X1.25
W30-12	W29-12	.75	.75	2.17	2.80	.937	2.000	1.38	.83	1.250	.614	1.050	.406	3/8-16	214	3/8-16X1.50
W30-16	W29-16	1.00	1.00	2.56	3.19	1.093	2.250	1.61	.83	1.560	.817	1.315	.492	7/16-14	219	7/16-14X1.75
W30-20	W29-20	1.25	1.25	3.07	3.75	1.250	2.625	1.73	.98	1.750	1.162	1.660	.531	1/2-13	222	1/2-13X1.75
W30-24	W29-24	1.50	1.50	3.70	4.41	1.437	3.125	2.17	1.18	2.115	1.340	1.900	.656	5/8-11	225	5/8-11X2.25
W30-32	W29-32	2.00	2.00	4.50	5.28	1.750	3.812	2.56	1.46	2.490	1.689	2.375	.781	3/4-10	228	3/4-10X3.00
*W30-40	*W29-40	2.50	2.50	5.00	6.88	2.312	4.875	2.37	1.50	2.995	2.127	2.875	.940	7/8-9	232	7/8-9X3.00
*W30-48	*W29-48	3.00	3.00	6.00	8.50	2.812	6.000	2.96	2.00	3.615	2.626	3.500	1.190	1 1/8-7	237	1 1/8-7X4.00

### CODE 62 BUTT WELD - SCHEDULE XXS PIPE

PART NO. O-RING FIG. 1	PART NO. FLAT FACE FIG. 2	PIPE SIZE	PAD SIZE	A	B	C	D	E	F	G	H	J	K	L UNC-2B	MOUNTING HARDWARE	
															O-RING	SHCS
W33-8	W32-8	.50	.50	1.81	2.21	.718	1.594	1.42	.63	1.000	.254	.840	.344	5/16-18	210	5/16-18X1.25
W33-12	W32-12	.75	.75	2.17	2.80	.937	2.000	1.38	.83	1.250	.436	1.050	.406	3/8-16	214	3/8-16X1.50
W33-16	W32-16	1.00	1.00	2.56	3.19	1.093	2.250	1.61	.83	1.560	.601	1.315	.492	7/16-14	219	7/16-14X1.75
W33-20	W32-20	1.25	1.25	3.07	3.75	1.250	2.625	1.73	.98	1.750	.898	1.660	.531	1/2-13	222	1/2-13X1.75
W33-24	W32-24	1.50	1.50	3.70	4.41	1.437	3.125	2.17	1.18	2.115	1.102	1.900	.656	5/8-11	225	5/8-11X2.25
W33-32	W32-32	2.00	2.00	4.50	5.28	1.750	3.812	2.56	1.46	2.490	1.505	2.375	.781	3/4-10	228	3/4-10X3.00
*W33-40	*W32-40	2.50	2.50	5.00	6.88	2.312	4.875	2.37	1.50	2.995	1.773	2.875	.940	7/8-9	232	7/8-9X3.00
*W33-48	*W32-48	3.00	3.00	6.00	8.50	2.812	6.000	2.96	2.00	3.615	2.302	3.500	1.190	1 1/8-7	237	1 1/8-7X4.00

\*Flange Shape Rectangle  
3000 PSI Max Working Pressure

# Saddle Weld

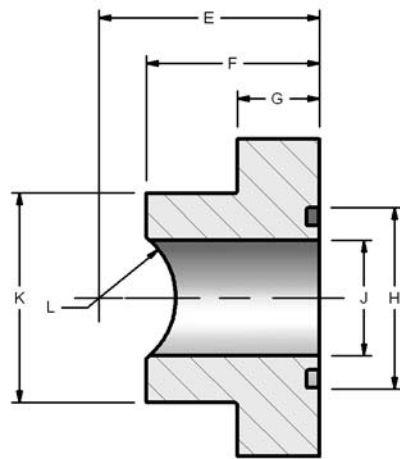
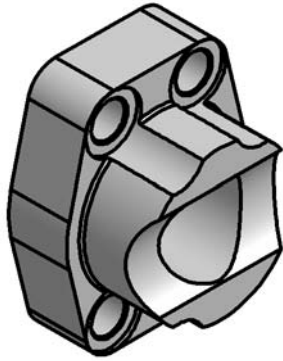

Figure 1

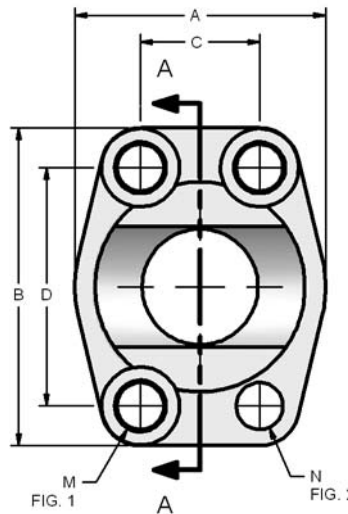

FIG. 1 A FIG. 2 N

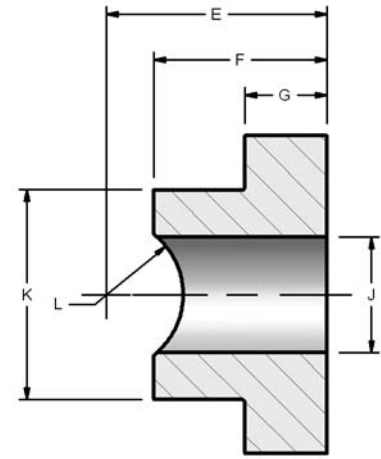

Figure 2

## CODE 61 SADDLE WELD - PIPE

PART NO. O-RING FIG. 1	PART NO. FLAT FACE FIG. 2	PIPE SIZE	PAD SIZE	A	B	C	D	E	F	G	H	J	K	L	M	N UNC-2B	MOUNTING HARDWARE	
																	O-RING	SHCS
W8-12-12	W7-12-12	.75	.75	1.97	2.56	.875	1.875	1.775	1.42	.71	1.250	.752	1.54	.532	.406	3/8-16	214	3/8-16X1.50
W8-16-16	W7-16-16	1.00	1.00	2.17	2.75	1.031	2.062	1.912	1.50	.71	1.560	1.002	1.81	.665	.406	3/8-16	219	3/8-16X1.50
W8-20-20	W7-20-20	1.25	1.25	2.68	3.12	1.188	2.312	2.146	1.61	.83	1.750	1.252	2.22	.837	.469	7/16-14	222	7/16-14X1.75
W8-24-24	W7-24-24	1.50	1.50	3.07	3.66	1.406	2.750	2.290	1.77	.98	2.115	1.502	2.50	.957	.531	1/2-13	225	1/2-13X1.75
W8-32-32	W7-32-32	2.00	2.00	3.54	4.00	1.688	3.062	2.340	1.77	.98	2.490	2.002	3.12	1.200	.531	1/2-13	228	1/2-13X1.75
W8-40-40	W7-40-40	3.50	2.50	4.09	4.49	2.000	3.500	2.660	1.97	.98	2.995	2.502	3.62	1.451	.531	1/2-13	232	1/2-13X1.75

## CODE 61 SADDLE WELD - TUBE

PART NO. O-RING FIG. 1	PART NO. FLAT FACE FIG. 2	TUBE SIZE	PAD SIZE	A	B	C	D	E	F	G	H	J	K	L	M	N UNC-2B	MOUNTING HARDWARE	
																	O-RING	SHCS
W87-12-12	W69-12-12	.75	.75	1.97	2.56	.875	1.875	1.420	1.42	.71	1.250	.752	1.54	.382	.406	3/8-16	214	3/8-16X1.50
W87-16-12	W69-16-12	1.00	.75	1.97	2.56	.875	1.875	1.737	1.42	.71	1.250	.752	1.54	.507	.406	3/8-16	214	3/8-16X1.50
W87-16-16	W69-16-16	1.00	1.00	2.17	2.75	1.031	2.062	1.500	1.50	.71	1.560	1.002	1.81	.507	.406	3/8-16	219	3/8-16X1.50
W87-20-16	W69-20-16	1.25	1.00	2.17	2.75	1.031	2.062	1.858	1.50	.71	1.560	1.002	1.81	.632	.406	3/8-16	219	3/8-16X1.50
W87-20-20	W69-20-20	1.25	1.25	2.68	3.12	1.188	2.312	1.665	1.61	.83	1.750	1.252	2.22	.632	.469	7/16-14	222	7/16-14X1.75
W87-24-20	W69-24-20	1.50	1.25	2.68	3.12	1.188	2.312	2.022	1.61	.83	1.750	1.252	2.22	.757	.469	7/16-14	222	7/16-14X1.75
W87-28-24	W69-28-24	1.75	1.50	3.07	3.66	1.406	2.750	2.198	1.77	.98	2.115	1.502	2.50	.882	.531	1/2-13	225	1/2-13X1.75
W87-32-32	W69-32-32	2.00	2.00	3.54	4.00	1.688	3.062	2.262	1.77	.98	2.490	1.691	2.38	1.007	.531	1/2-13	228	1/2-13X1.75
W87-36-32	W69-36-32	2.25	2.00	3.54	4.00	1.688	3.062	2.247	1.77	.98	2.490	2.002	3.12	1.132	.531	1/2-13	228	1/2-13X1.75

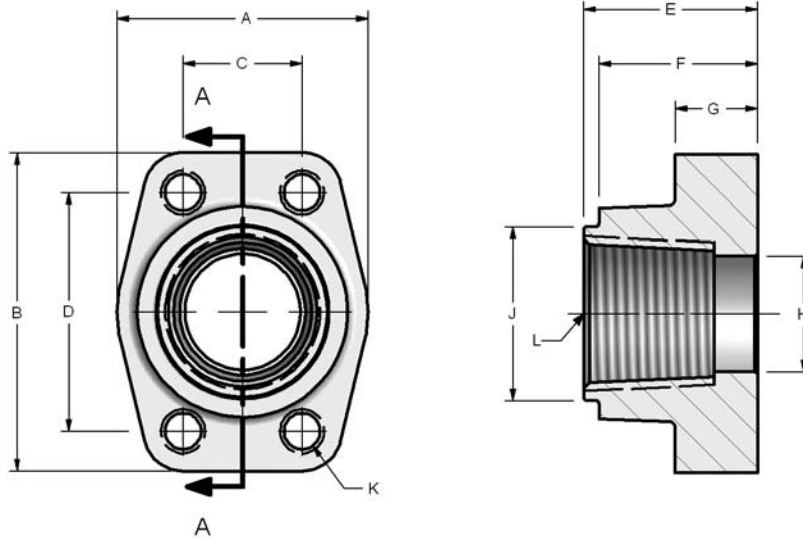
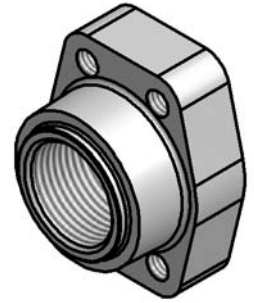

CODE 61 NPTF TANK PILOT													
PART NO. FLAT FACE	PIPE SIZE	PAD SIZE	A	B	C	D	E	F	G	H	J	K UNC-2B	L NPTF
W22-12	.750	.750	1.97	2.56	.875	1.875	1.42	1.30	.71	.752	1.375	3/8-16	3/4-14
W22-16	1.00	1.00	2.17	2.75	1.031	2.062	1.50	1.37	.71	1.002	1.500	3/8-16	1-11.5
W22-20	1.25	1.25	2.68	3.12	1.188	2.312	1.61	1.49	.83	1.252	1.750	7/16-14	1 1/4-11.5
W22-24	1.50	1.50	3.07	3.66	1.406	2.750	1.77	1.64	.98	1.502	2.125	1/2-13	1 1/2-11.5
W22-32	2.00	2.00	3.54	4.00	1.688	3.062	1.77	1.65	.98	2.002	2.500	1/2-13	2-11.5
W22-40	2.50	2.50	4.09	4.49	2.000	3.500	1.97	1.85	.98	2.502	3.250	1/2-13	2 1/2-8
W22-48	3.00	3.00	4.88	5.28	2.438	4.188	1.97	1.85	1.06	3.002	3.625	5/8-11	3-8
W22-56	3.50	3.50	5.35	5.98	2.750	4.750	1.89	1.77	1.06	3.504	4.125	5/8-11	3 1/2-8
W22-64	4.00	4.00	5.75	6.38	3.062	5.125	1.89	1.77	1.06	3.898	4.625	5/8-11	4-8

**Female NPTF thread added to facilitate pump suction line and return line applications.**

# Tee Junction Block

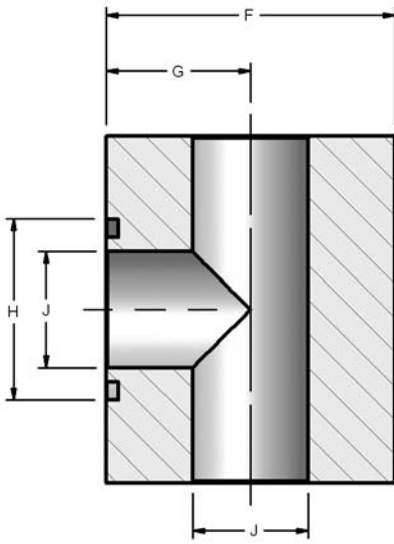
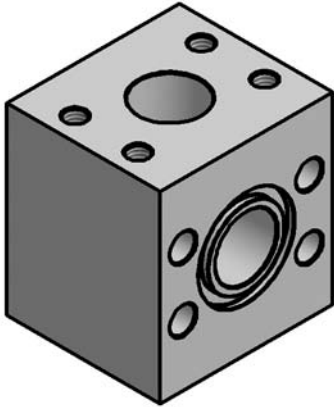

Figure 1

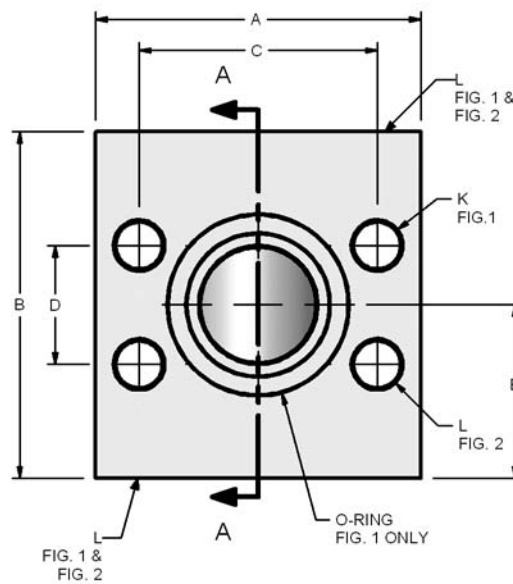

FIG. 1 & FIG. 2

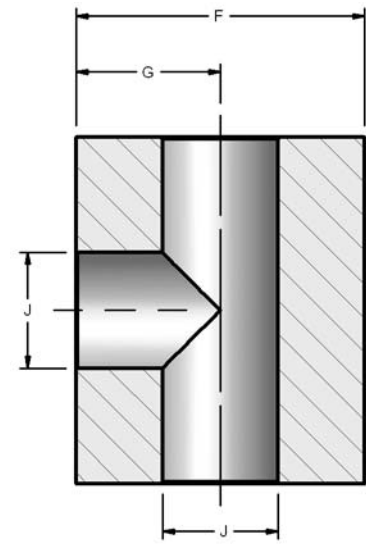

Figure 2

## CODE 61 TEE JUNCTION BLOCK

PART NO. O-RING FIG. 1	PART NO. FLAT FACE FIG. 2	PAD SIZE	A	B	C	D	E	F	G	H	J	K	L UNC-2B	MOUNTING HARDWARE	
														O-RING	SHCS
W17-12	W16-12	.75	2.62	2.75	1.875	.875	1.38	2.25	1.22	1.250	.75	.406	3/8-16	214	3/8-16X3.00
W17-16	W16-16	1.00	2.82	3.00	2.062	1.031	1.50	2.50	1.34	1.560	1.00	.406	3/8-16	219	3/8-16X3.25
W17-20	W16-20	1.25	3.19	3.50	2.312	1.188	1.75	3.00	1.56	1.750	1.25	.469	7/16-14	222	7/16-14X4.00
W17-24	W16-24	1.50	3.75	4.00	2.750	1.406	2.00	3.50	1.88	2.115	1.50	.531	1/2-13	225	1/2-13X4.50
W17-32	W16-32	2.00	4.00	4.25	3.062	1.688	2.12	4.00	2.09	2.490	2.00	.531	1/2-13	228	1/2-13X5.00

## CODE 62 TEE JUNCTION BLOCK

PART NO. O-RING FIG. 1	PART NO. FLAT FACE FIG. 2	PAD SIZE	A	B	C	D	E	F	G	H	J	K	L UNC-2B	MOUNTING HARDWARE	
														O-RING	SHCS
W19-12	W18-12	.75	2.81	3.00	2.00	.937	1.50	2.50	1.310	1.250	.750	.406	3/8-16	214	3/8-16X3.25
W19-16	W18-16	1.00	3.19	3.50	2.25	1.093	1.75	3.00	1.620	1.560	1.000	.492	7/16-14	219	7/16-14X4.00
W19-20	W18-20	1.25	3.75	4.00	2.625	1.250	2.00	3.50	1.880	1.750	1.250	.531	1/2-13	222	1/2-13X4.50
W19-24	W18-24	1.50	4.50	4.50	3.125	1.437	2.25	4.00	2.120	2.115	1.500	.656	5/8-11	225	5/8-11X5.00
W19-32	W18-32	2.00	5.25	5.00	3.812	1.750	2.50	5.00	2.750	2.490	1.940	.781	3/4-10	228	3/4-10X6.00

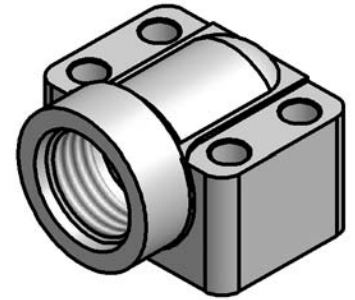
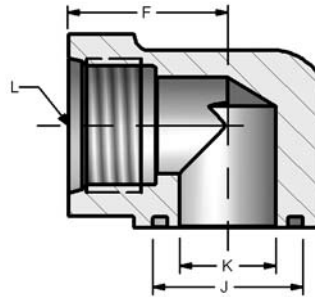
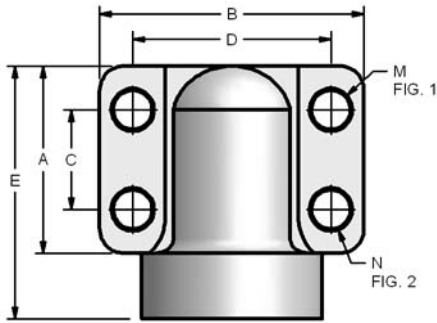

Figure 1

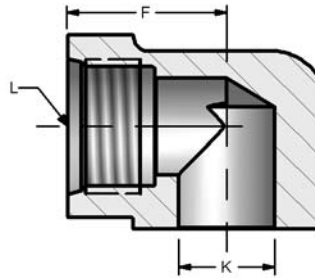
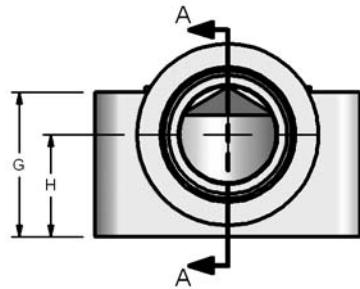

Figure 2

### CODE 61 ELBOW SAE STRAIGHT THREAD

PART NO. O-RING FIG. 1	PART NO. FLAT FACE FIG. 2	PAD SIZE	A	B	C	D	E	F	G	H	J	K	L UN-2B	M	N UNC-2B	MOUNTING HARDWARE	
																O-RING	SHCS
W164-12-12	W165-12-12	.75	1.69	2.56	.875	1.875	2.28	1.44	1.25	.875	1.250	.752	1-1/16-12	.406	3/8-16	214	3/8-16X2.00
W164-16-16	W165-16-16	1.00	1.94	2.75	1.031	2.062	2.62	1.66	1.50	1.062	1.560	1.002	1-5/16-12	.406	3/8-16	219	3/8-16X2.25
W164-20-20	W165-20-20	1.25	2.19	3.12	1.188	2.312	3.00	1.91	1.81	1.188	1.750	1.252	1-5/8-12	.469	7/16-14	222	7/16-14X2.75
W164-24-24	W165-24-24	1.50	2.56	3.69	1.406	2.750	3.33	2.05	2.00	1.312	2.115	1.502	1-7/8-12	.531	1/2-13	225	1/2-13X3.00
W164-32-32	W165-32-32	2.00	3.06	4.33	1.688	3.062	3.81	2.28	2.50	1.656	1.490	2.002	2-1/2-12	.531	1/2-13	228	1/2-13X3.50

### CODE 61 ELBOW NPTF THREAD

PART NO. O-RING FIG. 1	PART NO. FLAT FACE FIG. 2	PAD SIZE	A	B	C	D	E	F	G	H	J	K	L NPTF	M	N UNC-2B	MOUNTING HARDWARE	
																O-RING	SHCS
W168-12-12	W170-12-12	.75	1.69	2.56	.875	1.875	2.28	1.44	1.25	.875	1.250	.752	.75	.406	3/8-16	214	3/8-16X2.00
W168-16-16	W170-16-16	1.00	1.94	2.75	1.031	2.062	2.62	1.66	1.50	1.062	1.560	1.002	1.00	.406	3/8-16	219	3/8-16X2.25
W168-20-20	W170-20-20	1.25	2.19	3.12	1.188	2.312	3.00	1.91	1.81	1.188	1.750	1.252	1.25	.469	7/16-14	222	7/16-14X2.75
W168-24-24	W170-24-24	1.50	2.56	3.69	1.406	2.750	3.33	2.05	2.00	1.312	2.115	1.502	1.50	.531	1/2-13	225	1/2-13X3.00
W168-32-32	W170-32-32	2.00	3.06	4.33	1.688	3.062	3.81	2.28	2.50	1.656	2.490	2.002	2.00	.531	1/2-13	228	1/2-13X3.50

### CODE 62 ELBOW SAE STRAIGHT THREAD

PART NO. O-RING FIG. 1	PART NO. FLAT FACE FIG. 2	PAD SIZE	A	B	C	D	E	F	G	H	J	K	L UN-2B	M	N UNC-2B	MOUNTING HARDWARE	
																O-RING	SHCS
W184-12-12	W185-12-12	.75	1.94	2.75	.937	2.000	2.62	1.66	1.50	1.062	1.250	.752	1-1/16-12	.406	3/8-16	214	3/8-16X2.25
W184-16-16	W185-16-16	1.00	2.19	3.12	1.093	2.250	3.00	1.91	1.81	1.188	1.560	1.002	1-5/16-12	.492	7/16-14	219	7/16-14X2.50
W184-20-20	W185-20-20	1.25	2.56	3.69	1.250	2.625	3.32	2.05	2.00	1.312	1.750	1.252	1-5/8-12	.531	1/2-13	222	1/2-13X3.00
W184-24-24	W185-24-24	1.50	3.06	4.33	1.437	3.125	3.81	2.28	2.50	1.656	2.115	1.502	1-7/8-12	.656	5/8-11	225	5/8-11X3.50

### CODE 62 ELBOW NPTF THREAD

PART NO. O-RING FIG. 1	PART NO. FLAT FACE FIG. 2	PAD SIZE	A	B	C	D	E	F	G	H	J	K	L NPTF	M	N UNC-2B	MOUNTING HARDWARE	
																O-RING	SHCS
W188-12-12	W180-12-12	.75	1.94	2.75	.937	2.000	2.62	1.66	1.50	1.062	1.250	.752	.75	.406	3/8-16	214	3/8-16X2.25
W188-16-16	W180-16-16	1.00	2.19	3.12	1.093	2.250	3.00	1.91	1.81	1.188	1.560	1.002	1.00	.492	7/16-14	219	7/16-14X2.50
W188-20-20	W180-20-20	1.25	2.56	3.69	1.250	2.625	3.32	2.05	2.00	1.312	1.750	1.252	1.25	.531	1/2-13	222	1/2-13X3.00
W188-24-24	W180-24-24	1.50	3.06	4.33	1.437	3.125	3.81	2.28	2.50	1.656	2.115	1.502	1.50	.656	5/8-11	225	5/8-11X3.50

# Socket Weld Elbow

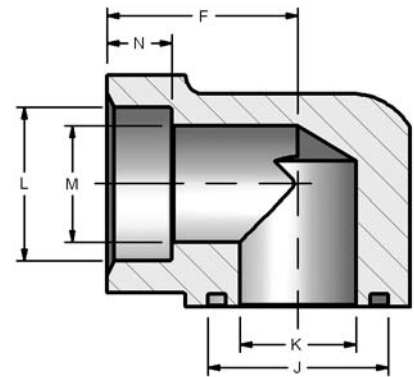
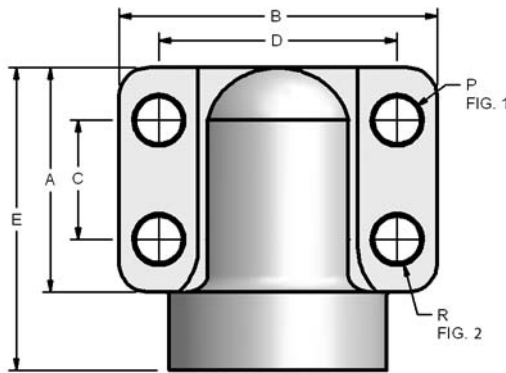
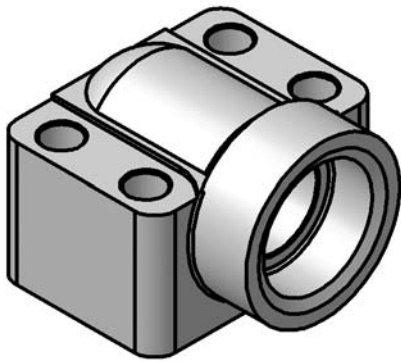

Figure 1

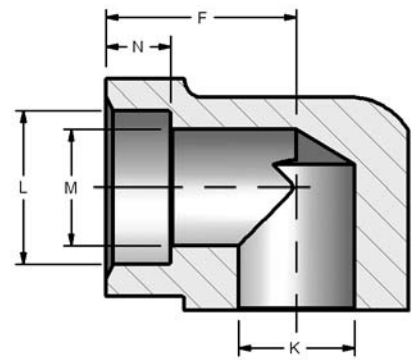
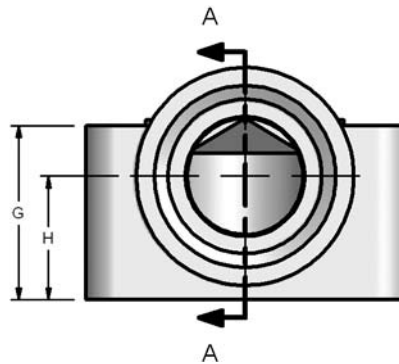

Figure 2

## CODE 61 ELBOW SOCKET WELD - PIPE

PART NO. O-RING FIG. 1	PART NO. FLAT FACE FIG. 2	PAD SIZE	A	B	C	D	E	F	G	H	J	K	L	M	N	P	R UNC-2B	MOUNTING HARDWARE	
																		O-RING	SHCS
W176-12-12	W169-12-12	.75	1.69	2.56	.875	1.875	2.28	1.44	1.25	.875	1.250	.752	1.062	.75	.56	.406	3/8-16	214	3/8-16X2.00
W176-16-16	W169-16-16	1.00	1.94	2.75	1.031	2.062	2.62	1.66	1.50	1.062	1.560	1.002	1.328	1.00	.56	.406	3/8-16	219	3/8-16X2.25
W176-20-20	W169-20-20	1.25	2.19	3.12	1.188	2.312	3.00	1.91	1.81	1.188	1.750	1.252	1.672	1.25	.62	.469	7/16-14	222	7/16-14X2.75
W176-24-24	W169-24-24	1.50	2.56	3.69	1.406	2.750	3.33	2.05	2.00	1.312	2.115	1.502	1.922	1.50	.69	.531	1/2-13	225	1/2-13X3.00
W176-32-32	W169-32-32	2.00	3.06	4.33	1.688	3.062	3.81	2.28	2.50	1.656	2.490	2.002	2.406	2.00	.75	.531	1/2-13	228	1/2-13X3.50
W176-40-40	W169-40-40	CONSULT PAGE 45 FOR DIMENSIONS																	
W176-48-48	W169-48-48	CONSULT PAGE 45 FOR DIMENSIONS																	

## CODE 61 ELBOW SOCKET WELD - TUBE

PART NO. O-RING FIG. 1	PART NO. FLAT FACE FIG. 2	PAD SIZE	A	B	C	D	E	F	G	H	J	K	L	M	N	P	R UNC-2B	MOUNTING HARDWARE	
																		O-RING	SHCS
W172-12-12	W177-12-12	.75	1.69	2.56	.875	1.875	2.28	1.44	1.25	.875	1.250	.752	.752	.625	.312	.406	3/8-16	214	3/8-16X2.00
W172-16-12	W177-16-12	.75	1.69	2.56	.875	1.875	2.28	1.44	1.25	.875	1.250	.752	1.002	.750	.438	.406	3/8-16	214	3/8-16X2.00
W172-16-16	W177-16-16	1.00	1.94	2.75	1.031	2.062	2.62	1.66	1.50	1.062	1.560	1.002	1.002	.875	.438	.406	3/8-16	219	3/8-16X2.25
W172-20-16	W177-20-16	1.00	1.94	2.75	1.031	2.062	2.62	1.66	1.50	1.062	1.560	1.002	1.252	1.000	.500	.406	3/8-16	219	3/8-16X2.25
W172-20-20	W177-20-20	1.25	2.19	3.12	1.188	2.312	3.00	1.91	1.81	1.188	1.750	1.252	1.252	1.125	.500	.469	7/16-14	222	7/16-14X2.75
W172-24-20	W177-24-20	1.25	2.19	3.12	1.188	2.312	3.00	1.91	1.81	1.188	1.750	1.252	1.502	1.250	.562	.469	7/16-14	222	7/16-14X2.75
W172-24-24	W177-24-24	1.50	2.56	3.69	1.406	2.750	3.33	2.05	2.00	1.312	2.115	1.502	1.502	1.375	.562	.531	1/2-13	225	1/2-13X3.00
W172-28-24	W177-28-24	1.50	2.56	3.69	1.406	2.750	3.33	2.05	2.00	1.312	2.115	1.502	1.752	1.500	.562	.531	1/2-13	225	1/2-13X3.00
W172-32-32	W177-32-32	2.00	3.06	4.33	1.688	3.062	3.81	2.28	2.50	1.656	2.490	2.002	2.002	1.875	.625	.531	1/2-13	228	1/2-13X3.50
W172-36-32	W177-36-32	2.00	3.06	4.33	1.688	3.062	3.81	2.28	2.50	1.656	2.490	2.002	2.252	2.000	.625	.531	1/2-13	228	1/2-13X3.50

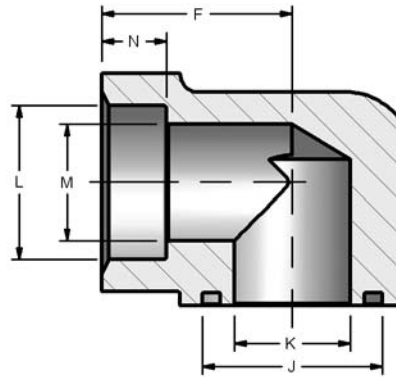
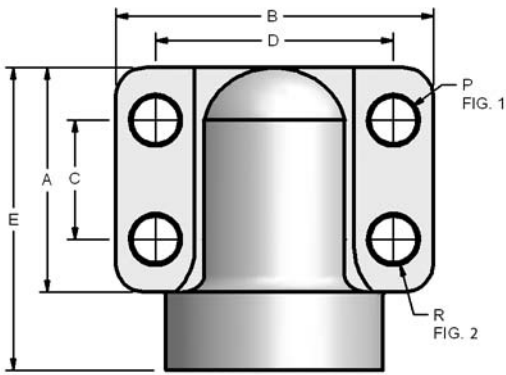

Figure 1

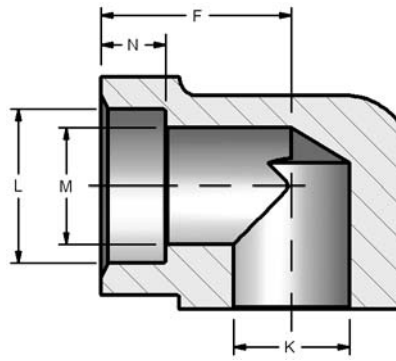
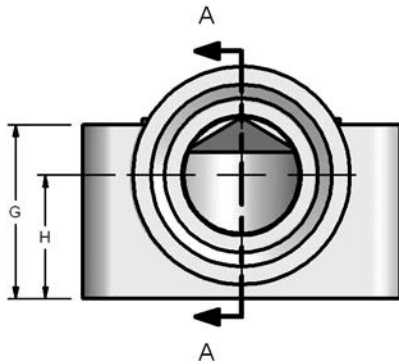
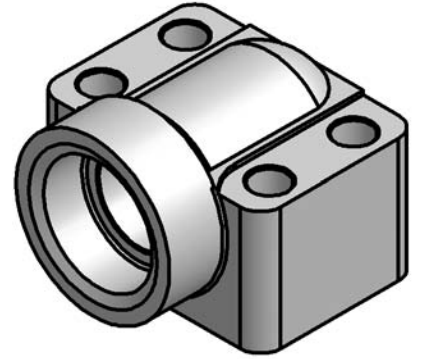

Figure 2

### CODE 62 ELBOW SOCKET WELD - PIPE

PART NO. O-RING FIG. 1	PART NO. FLAT FACE FIG. 2	PAD SIZE	A	B	C	D	E	F	G	H	J	K	L	M	N	P	R UNC-2B	MOUNTING HARDWARE	
																		O-RING	SHCS
W186-12-12	W189-12-12	.75	1.94	2.75	.937	2.000	2.62	1.66	1.50	1.062	1.250	.752	1.062	.75	.56	.406	3/8-16	214	3/8-16X2.25
W186-16-16	W189-16-16	1.00	2.19	3.12	1.093	2.250	3.00	1.91	1.81	1.188	1.560	1.002	1.328	1.00	.62	.492	7/16-14	219	7/16-14X2.50
W186-20-20	W189-20-20	1.25	2.56	3.69	1.250	2.625	3.32	2.05	2.00	1.312	1.750	1.252	1.672	1.25	.69	.531	1/2-13	222	1/2-13X3.00
W186-24-24	W189-24-24	1.50	3.06	4.33	1.437	3.125	3.81	2.28	2.50	1.656	2.115	1.502	1.922	1.50	.75	.656	5/8-11	225	5/8-11X3.50

### CODE 62 ELBOW SOCKET WELD - TUBE

PART NO. O-RING FIG. 1	PART NO. FLAT FACE FIG. 2	PAD SIZE	A	B	C	D	E	F	G	H	J	K	L	M	N	P	R UNC-2B	MOUNTING HARDWARE	
																		O-RING	SHCS
W182-12-12	W187-12-12	.75	1.94	2.75	.937	2.000	2.62	1.66	1.50	1.062	1.250	.752	.752	.625	.56	.406	3/8-16	214	3/8-16X2.25
W182-16-12	W187-16-12	.75	1.94	2.75	.937	2.000	2.62	1.66	1.50	1.062	1.250	.752	1.002	.750	.62	.406	3/8-16	214	3/8-16X2.25
W182-16-16	W187-16-16	1.00	2.19	3.12	1.093	2.250	3.00	1.91	1.81	1.188	1.560	1.002	1.002	.875	.62	.492	7/16-14	219	7/16-14X2.50
W182-20-16	W187-20-16	1.00	2.19	3.12	1.093	2.250	3.00	1.91	1.81	1.188	1.560	1.002	1.252	1.000	.69	.492	7/16-14	219	7/16-14X2.50
W182-20-20	W187-20-20	1.25	2.56	3.69	1.250	2.625	3.32	2.05	2.00	1.312	1.750	1.252	1.252	1.125	.69	.531	1/2-13	222	1/2-13X3.00
W182-24-20	W187-24-20	1.25	2.56	3.69	1.250	2.625	3.32	2.05	2.00	1.312	1.750	1.252	1.502	1.250	.75	.531	1/2-13	222	1/2-13X3.00
W182-24-24	W187-24-24	1.50	3.06	4.33	1.437	3.125	3.81	2.28	2.50	1.656	2.115	1.502	1.502	1.375	.75	.656	5/8-11	225	5/8-11X3.50
W182-28-24	W187-28-24	1.50	3.06	4.33	1.437	3.125	3.81	2.28	2.50	1.656	2.115	1.502	1.752	1.500	.75	.656	5/8-11	225	5/8-11X3.50

# 3000 Series Square Pattern

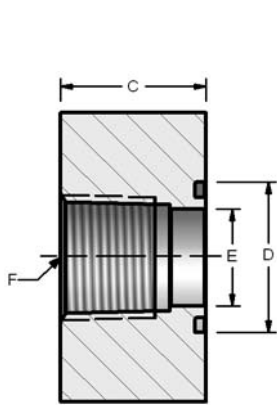
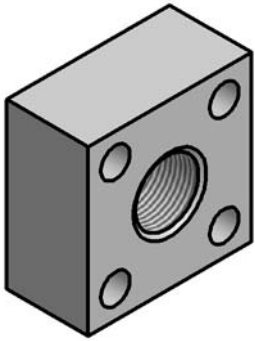

Figure 1

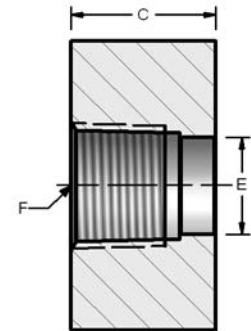
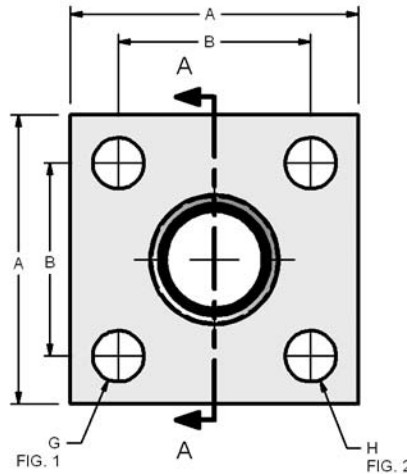

Figure 2

## 3000 SERIES SQUARE NPTF THREAD

PART NO. O-RING FIG. 1	PART NO. FLAT FACE FIG. 2	PAD SIZE	A	B	C	D	E	F NPTF	G	H UNC-2B	MOUNTING HARDWARE	
											O-RING	SHCS
W65-12	W75-12	.75	2.25	1.438	1.25	1.250	.752	.75	.406	3/8-16	214	3/8-16X2.00
W65-16	W75-16	1.00	3.00	2.000	1.50	1.560	1.002	1.00	.531	1/2-13	219	1/2-13X2.25
W65-20	W75-20	1.25	3.00	2.000	1.50	1.750	1.252	1.25	.531	1/2-13	222	1/2-13X2.25
W65-24	W75-24	1.50	4.00	2.750	1.75	2.115	1.502	1.50	.656	5/8-11	225	5/8-11X2.75
W65-32	W75-32	2.00	4.00	2.750	1.75	2.490	2.002	2.00	.656	5/8-11	228	5/8-11X2.75
W65-40	W75-40	2.50	5.50	3.750	2.25	2.995	2.502	2.50	.906	7/8-9	232	7/8-9X3.50
W65-48	W75-48	3.00	5.50	3.750	2.25	3.615	3.002	3.00	.906	7/8-9	237	7/8-9X3.50

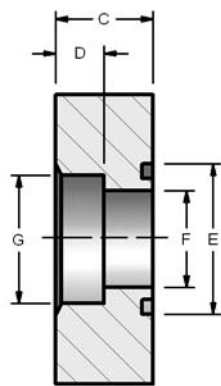
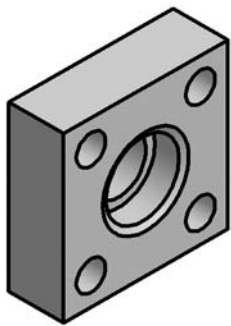

Figure 1

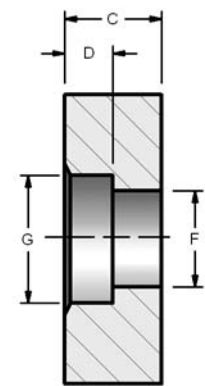
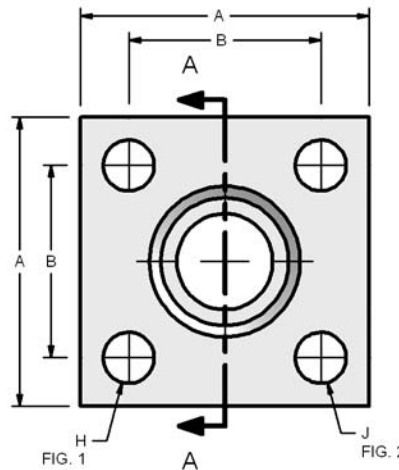

Figure 2

## 3000 SERIES SQUARE SOCKET WELD - PIPE

PART NO. O-RING FIG. 1	PART NO. FLAT FACE FIG. 2	PAD SIZE	A	B	C	D	E	F	G	H	J UNC-2B	MOUNTING HARDWARE	
												O-RING	SHCS
W66-12	W76-12	.75	2.25	1.438	1.00	.50	1.250	.752	1.062	.406	3/8-16	214	3/8-16X1.75
W66-16	W76-16	1.00	3.00	2.000	1.00	.50	1.560	1.002	1.328	.531	1/2-13	219	1/2-13X1.75
W66-20	W76-20	1.25	3.00	2.000	1.00	.50	1.750	1.252	1.672	.531	1/2-13	222	1/2-13X1.75
W66-24	W76-24	1.50	4.00	2.750	1.25	.62	2.115	1.502	1.922	.656	5/8-11	225	5/8-11X2.25
W66-32	W76-32	2.00	4.00	2.750	1.25	.62	2.490	2.002	2.406	.656	5/8-11	228	5/8-11X2.25
W66-40	W76-40	2.50	5.50	3.750	1.50	.75	2.995	2.502	2.906	.906	7/8-9	232	7/8-9X2.75
W66-48	W76-48	3.00	5.50	3.750	1.50	.75	3.615	3.002	3.547	.906	7/8-9	237	7/8-9X2.75

# Stainless Steel

The standard grade of material for Anchor's stainless steel flanges is 316L. Other material grades are available upon request. In addition, material grades and flange dimensions may vary due to availability of raw material.

# J518 Split & Captive Flange



CODE 61 SPLIT FLANGE													
PART NO.	**KIT PART NO.	FLANGE SIZE	A	B	C	D	E	F	G	H	J	MOUNTING HARDWARE	
												O-RING	HHCS
8SF-2-SS	8SFO-SS	.50	.86	2.12	1.500	.75	.50	1.219	.955	.245	.344	210	5/16-18X1.25
12SF-2-SS	12SFO-SS	.75	.98	2.56	1.875	.88	.56	1.531	1.265	.245	.406	214	3/8-16X1.25
16SF-2-SS	16SFO-SS	1.00	1.11	2.75	2.062	.94	.62	1.781	1.515	.295	.406	219	3/8-16X1.25
20SF-2-SS	20SFO-SS	1.25	1.39	3.12	2.312	.88	.56	2.031	1.720	.295	.469	222	7/16-14X1.50
24SF-2-SS	24SFO-SS	1.50	1.58	3.69	2.750	1.00	.62	2.406	2.000	.295	.531	225	1/2-13X1.50
32SF-2-SS	32SFO-SS	2.00	1.86	4.00	3.062	1.03	.62	2.844	2.470	.355	.531	228	1/2-13X1.50
40SF-2-SS	40SFO-SS	2.50	2.09	4.50	3.500	1.50	.75	3.344	2.950	.355	.531	232	1/2-13X1.75
48SF-2-SS	48SFO-SS	3.00	2.53	5.31	4.188	1.62	.88	4.031	3.580	.355	.656	237	5/8-11X1.75
56SF-2-SS	56SFO-SS	3.50	2.70	6.00	4.750	1.12	.88	4.531	4.030	.422	.656	241	5/8-11X2.00
64SF-2-SS	64SFO-SS	4.00	2.95	6.38	5.125	1.38	1.00	5.031	4.530	.422	.656	245	5/8-11X2.00

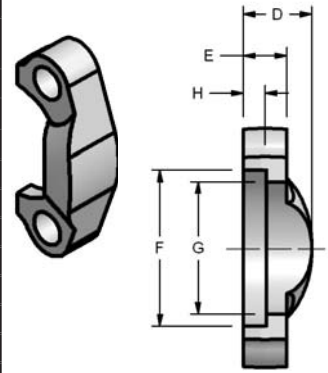

CODE 62 SPLIT FLANGE													
PART NO.	**KIT PART NO.	FLANGE SIZE	A	B	C	D	E	F	G	H	J	MOUNTING HARDWARE	
												O-RING	HHCS
8SFX-2-SS	8SFXO-SS	.50	.89	2.22	1.594	.88	.62	1.281	.970	.285	.344	210	5/16-18X1.50
12SFX-2-SS	12SFXO-SS	.75	1.14	2.81	2.000	1.12	.75	1.656	1.280	.325	.406	214	3/8-16X1.50
16SFX-2-SS	16SFXO-SS	1.00	1.33	3.19	2.250	1.31	.94	1.906	1.530	.355	.469	219	7/16-14X1.75
20SFX-2-SS	20SFXO-SS	1.25	1.48	3.75	2.625	1.50	1.06	2.156	1.750	.385	.531	222	1/2-13X1.75
24SFX-2-SS	24SFXO-SS	1.50	1.83	4.44	3.125	1.69	1.19	2.531	2.030	.475	.656	225	5/8-11X2.25
32SFX-2-SS	32SFXO-SS	2.00	2.20	5.25	3.812	2.06	1.44	3.156	2.660	.475	.781	228	3/4-10X2.75

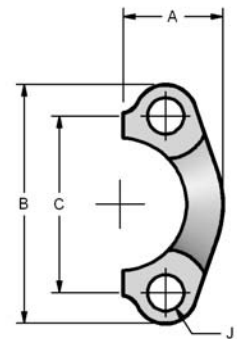

\*\*When ordering this part # you will receive:(2) split flange halves, (4) hex head bolts and lockwashers, and (1) Viton O-Ring

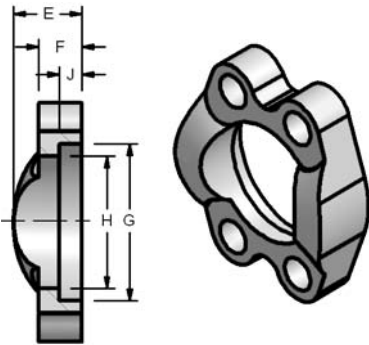

CODE 61 CAPTIVE FLANGE															
DRILLED PART NO.	TAPPED PART NO.	FLANGE SIZE	A	B	C	D	E	F	G	H	J	K	K UNC-2B		
8SFW-SS	8SFTW-SS	.50	1.81	2.12	.688	1.500	.75	.50	1.219	.955	.245	.344	5/16-18		
12SFW-SS	12SFTW-SS	.75	2.06	2.56	.875	1.875	.88	.56	1.531	1.265	.245	.406	3/8-16		
16SFW-SS	16SFTW-SS	1.00	2.31	2.75	1.031	2.062	.94	.62	1.781	1.515	.295	.406	3/8-16		
20SFW-SS	20SFTW-SS	1.25	2.88	3.12	1.188	2.312	.88	.56	2.031	1.720	.295	.469	7/16-14		
24SFW-SS	24SFTW-SS	1.50	3.25	3.69	1.406	2.750	1.00	.62	2.406	2.000	.295	.531	1/2-13		
32SFW-SS	32SFTW-SS	2.00	3.81	4.00	1.688	3.062	1.03	.62	2.844	2.470	.355	.531	1/2-13		
40SFW-SS	40SFTW-SS	2.50	4.28	4.50	2.000	3.500	1.50	.75	3.344	2.950	.355	.531	1/2-13		
48SFW-SS	48SFTW-SS	3.00	5.16	5.31	2.438	4.188	1.62	.88	4.031	3.580	.355	.656	5/8-11		
56SFW-SS	56SFTW-SS	3.50	5.50	6.00	2.750	4.750	1.12	.88	4.531	4.030	.422	.656	5/8-11		
64SFW-SS	64SFTW-SS	4.00	6.00	6.38	3.062	5.125	1.38	1.00	5.031	4.530	.422	.656	5/8-11		

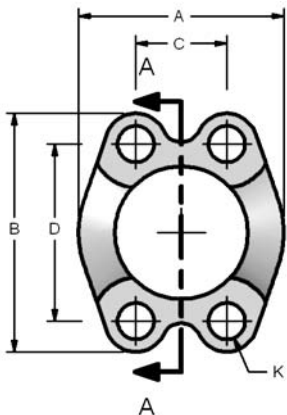

CODE 62 CAPTIVE FLANGE															
DRILLED PART NO.	TAPPED PART NO.	FLANGE SIZE	A	B	C	D	E	F	G	H	J	K	K UNC-2B		
8SFXW-SS	8SFXTW-SS	.50	1.86	2.22	.718	1.594	.88	.62	1.281	.970	.285	.344	5/16-18		
12SFXW-SS	12SFXTW-SS	.75	2.38	2.81	.937	2.000	1.12	.75	1.656	1.280	.325	.406	3/8-16		
16SFXW-SS	16SFXTW-SS	1.00	2.75	3.19	1.093	2.250	1.31	.94	1.906	1.530	.355	.469	7/16-14		
20SFXW-SS	20SFXTW-SS	1.25	3.06	3.75	1.250	2.625	1.50	1.06	2.156	1.750	.385	.531	1/2-13		
24SFXW-SS	24SFXTW-SS	1.50	3.75	4.44	1.437	3.125	1.69	1.19	2.531	2.030	.475	.656	5/8-11		
32SFXW-SS	32SFXTW-SS	2.00	4.50	5.25	1.750	3.812	2.06	1.44	3.156	2.660	.475	.781	3/4-10		

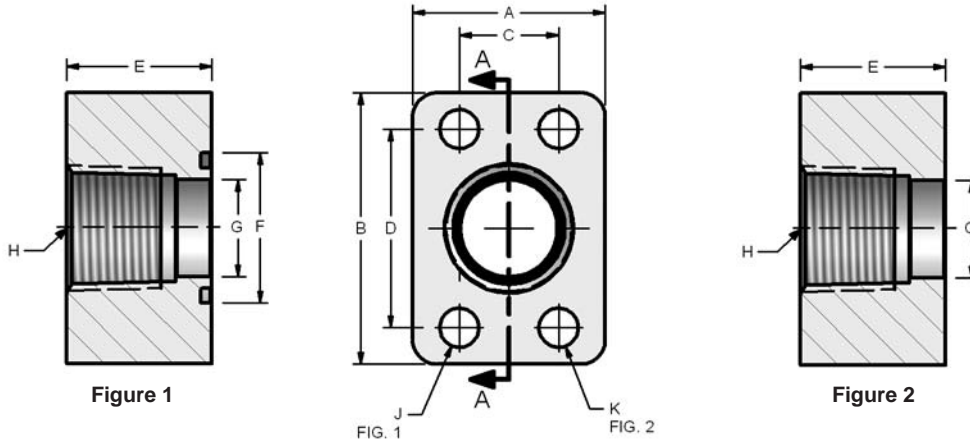
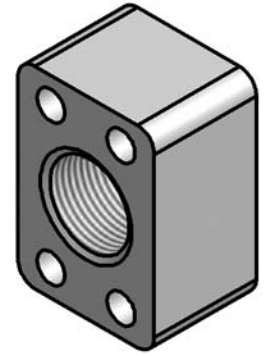

### CODE 61 NPTF THREAD

PART NO. O-RING FIG. 1	PART NO. FLAT FACE FIG. 2	PIPE SIZE	PAD SIZE	A	B	C	D	E	F	G	H NPTF	J	K UNC-2B	MOUNTING HARDWARE	
														O-RING	SHCS
W43-8-8-SS	W104-8-8-SS	.50	.50	1.50	2.12	.688	1.500	1.20	1.000	.502	.50	.344	5/16-18	210	5-16-18X1.75
W43-12-12-SS	W104-12-12-SS	.75	.75	1.75	2.62	.875	1.875	1.20	1.250	.752	.75	.406	3/8-16	214	3/8-16X2.00
W43-16-16-SS	W104-16-16-SS	1.00	1.00	2.00	2.82	1.031	2.062	1.45	1.560	1.002	1.00	.406	3/8-16	219	3/8-16X2.25
W43-20-20-SS	W104-20-20-SS	1.25	1.25	2.50	3.19	1.188	2.312	1.45	1.750	1.252	1.25	.469	7/16-14	222	7/16-14X2.25
W43-24-24-SS	W104-24-24-SS	1.50	1.50	2.75	3.75	1.406	2.750	1.70	2.115	1.502	1.50	.531	1/2-13	225	1/2-13X2.50
W43-32-32-SS	W104-32-32-SS	2.00	2.00	3.25	4.00	1.688	3.062	1.70	2.490	2.002	2.00	.531	1/2-13	228	1/2-13X2.50
W43-40-40-SS	W104-40-40-SS	2.50	2.50	4.00	4.50	2.000	3.500	1.95	2.995	2.502	2.50	.531	1/2-13	232	1/2-13X2.75
W43-48-48-SS	W104-48-48-SS	3.00	3.00	4.50	5.31	2.438	4.188	2.20	3.615	3.002	3.00	.656	5/8-11	237	5/8-11X3.00

### CODE 62 NPTF THREAD

PART NO. O-RING FIG. 1	PART NO. FLAT FACE FIG. 2	PIPE SIZE	PAD SIZE	A	B	C	D	E	F	G	H NPTF	J	K UNC-2B	MOUNTING HARDWARE	
														O-RING	SHCS
W44-8-8-SS	W45-8-8-SS	.50	.50	1.75	2.22	.718	1.594	.95	1.000	.502	.50	.344	5/16-18	210	5/16-18X1.50
W44-12-12-SS	W45-12-12-SS	.75	.75	2.00	2.81	.937	2.000	1.20	1.250	.752	.75	.406	3/8-16	214	3/8-16X2.00
W44-16-16-SS	W45-16-16-SS	1.00	1.00	2.25	3.19	1.093	2.250	1.45	1.560	1.002	1.00	.492	7/16-14	219	7/16-14X2.50
W44-20-20-SS	W45-20-20-SS	1.25	1.25	2.75	3.75	1.250	2.625	1.45	1.750	1.252	1.25	.531	1/2-13	222	1/2-13X2.25
W44-24-24-SS	W45-24-24-SS	1.50	1.50	3.25	4.50	1.437	3.125	1.70	2.115	1.502	1.50	.656	5/8-11	225	5/8-11X2.75
W44-32-32-SS	W45-32-32-SS	2.00	2.00	4.00	5.25	1.750	3.812	1.70	2.490	2.002	2.00	.781	3/4-10	228	3/4-10X3.00

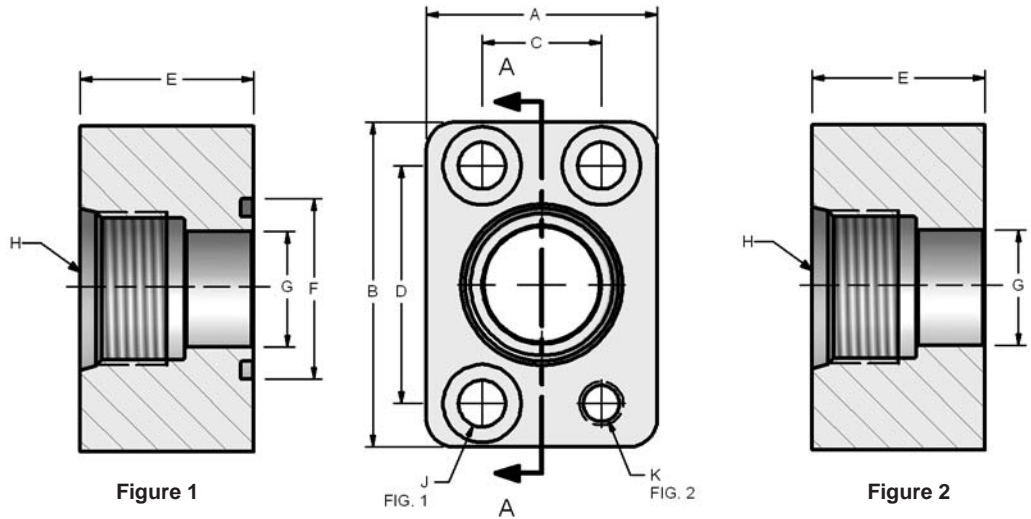
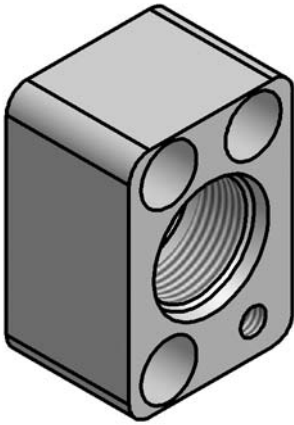

### CODE 61 SAE STRAIGHT THREAD

PART NO. O-RING FIG. 1	PART NO. FLAT FACE FIG. 2	TUBE SIZE	PAD SIZE	A	B	C	D	E	F	G	H UN/ UNF-2B	J	K UNC-2B	MOUNTING HARDWARE	
														O-RING	SHCS
W46-8-8-SS	W106-8-8-SS	.50	.50	1.50	2.12	.688	1.500	1.20	1.000	.502	3/4-16	.344	5/16-18	210	5-16-18X1.25
W46-12-12-SS	W106-12-12-SS	.75	.75	1.75	2.62	.875	1.875	1.20	1.250	.752	1 1/16-12	.406	3/8-16	214	3/8-16X1.50
W46-16-16-SS	W106-16-16-SS	1.00	1.00	2.00	2.82	1.031	2.062	1.45	1.560	1.002	1 5/16-12	.406	3/8-16	219	3/8-16X1.50
W46-20-20-SS	W106-20-20-SS	1.25	1.25	2.50	3.19	1.188	2.312	1.45	1.750	1.252	1 5/8-12	.469	7/16-14	222	7/16-14X1.75
W46-24-24-SS	W106-24-24-SS	1.50	1.50	2.75	3.75	1.406	2.750	1.70	2.115	1.502	1 7/8-12	.531	1/2-13	225	1/2-13X2.00
*W46-32-32-SS	W106-32-32-SS	2.00	2.00	3.25	4.00	1.688	3.062	1.70	2.490	2.002	2 1/2-12	.531	1/2-13	228	1/2-13X2.00

\*NOTE: 500 PSI max for W46-32-32-SS

### CODE 62 SAE STRAIGHT THREAD

PART NO. O-RING FIG. 1	PART NO. FLAT FACE FIG. 2	TUBE SIZE	PAD SIZE	A	B	C	D	E	F	G	H UN/ UNF-2B	J	K UNC-2B	MOUNTING HARDWARE	
														O-RING	SHCS
W48-8-8-SS	W49-8-8-SS	.50	.50	1.75	2.22	.718	1.594	.95	1.000	.502	3/4-16	.344	5/16-18	210	5/16-18X1.25
W48-12-12-SS	W49-12-12-SS	.75	.75	2.00	2.81	.937	2.000	1.20	1.250	.752	1 1/16-12	.406	3/8-16	214	3/8-16X1.50
W48-16-16-SS	W49-16-16-SS	1.00	1.00	2.25	3.19	1.093	2.250	1.45	1.560	1.002	1 5/16-12	.492	7/16-14	219	7/16-14X1.75
W48-20-20-SS	W49-20-20-SS	1.25	1.25	2.75	3.75	1.250	2.625	1.45	1.750	1.252	1 5/8-12	.531	1/2-13	222	1/2-13X1.50
W48-24-24-SS	W49-24-24-SS	1.50	1.50	3.25	4.50	1.437	3.125	1.70	2.115	1.502	1 7/8-12	.656	5/8-11	225	5/8-11X2.00
W48-32-32-SS	W49-32-32-SS	2.00	2.00	4.00	5.25	1.750	3.812	1.70	2.490	2.002	2 1/2-12	.781	3/4-10	228	3/4-10X2.00

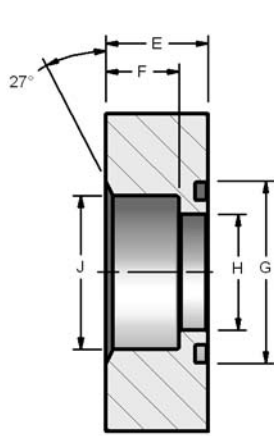

Figure 1

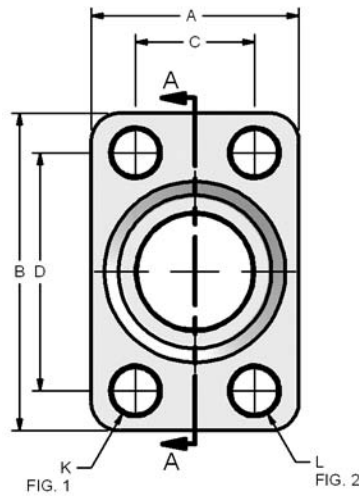

FIG. 1 FIG. 2

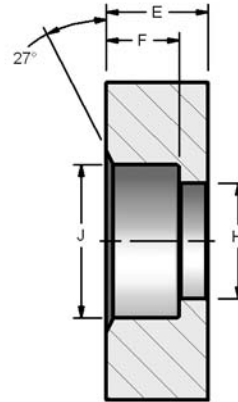
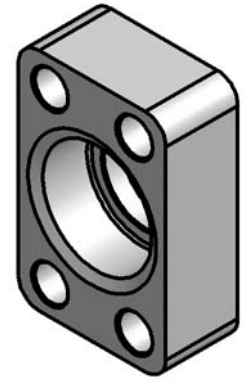

Figure 2



CODE 61 FLAT SOCKET WELD - PIPE																
PART NO. O-RING FIG. 1	PART NO. FLAT FACE FIG. 2	PIPE SIZE	PAD SIZE	A	B	C	D	E	F	G	H	J	K	L UNC-2B	MOUNTING HARDWARE	
															O-RING	SHCS
W4-8-8-SS	W61-8-8-SS	.50	.50	1.50	2.12	.688	1.500	.69	.38	1.000	.502	.860	.344	5/16-18	210	5/16-18X1.25
W4-12-12-SS	W61-12-12-SS	.75	.75	1.75	2.62	.875	1.875	.94	.50	1.250	.752	1.070	.406	3/8-16	214	3/8-16X1.75
W4-16-16-SS	W61-16-16-SS	1.00	1.00	2.00	2.82	1.031	2.062	.94	.50	1.560	1.002	1.335	.406	3/8-16	219	3/8-16X1.75
W4-20-20-SS	W61-20-20-SS	1.25	1.25	2.50	3.19	1.188	2.312	.94	.50	1.750	1.252	1.680	.469	7/16-14	222	7/16-14X1.75
W4-24-24-SS	W61-24-24-SS	1.50	1.50	2.75	3.75	1.406	2.750	1.19	.50	2.115	1.502	1.920	.531	1/2-13	225	1/2-13X2.25
W4-32-32-SS	W61-32-32-SS	2.00	2.00	3.25	4.00	1.688	3.062	1.44	.62	2.490	2.002	2.411	.531	1/2-13	228	1/2-13X2.50
W4-40-40-SS	W61-40-40-SS	2.50	2.50	4.00	4.50	2.000	3.500	1.69	.75	2.995	2.502	2.911	.531	1/2-13	232	1/2-13X2.75
W4-48-48-SS	W61-48-48-SS	3.00	3.00	4.50	5.31	2.438	4.188	2.12	1.24	3.615	3.002	3.540	.656	5/8-11	237	5/8-11X3.50

CODE 62 FLAT SOCKET WELD - PIPE																
PART NO. O-RING FIG. 1	PART NO. FLAT FACE FIG. 2	PIPE SIZE	PAD SIZE	A	B	C	D	E	F	G	H	J	K	L UNC-2B	MOUNTING HARDWARE	
															O-RING	SHCS
W59-8-8-SS	W60-8-8-SS	.50	.50	1.75	2.22	.718	1.594	.940	.50	1.000	.502	.860	.344	5/16-18	210	5/16-18X1.50
W59-12-12-SS	W60-12-12-SS	.75	.75	2.00	2.81	.937	2.000	.940	.50	1.250	.752	1.070	.406	3/8-16	214	3/8-16X1.75
W59-16-16-SS	W60-16-16-SS	1.00	1.00	2.25	3.19	1.093	2.250	.940	.50	1.560	1.002	1.335	.492	7/16-14	219	7/16-14X1.75
W59-20-20-SS	W60-20-20-SS	1.25	1.25	2.75	3.75	1.250	2.625	1.19	.50	1.750	1.252	1.672	.531	1/2-13	222	1/2-13X2.25
W59-24-24-SS	W60-24-24-SS	1.50	1.50	3.25	4.50	1.437	3.125	1.44	.50	2.115	1.502	1.920	.656	5/8-11	225	5/8-11X2.75
W59-32-32-SS	W60-32-32-SS	2.00	2.00	4.00	5.25	1.750	3.812	1.69	.62	2.490	2.002	2.411	.781	3/4-10	228	3/4-10X3.00
W59-40-40-SS	W60-40-40-SS	2.50	2.50	5.00	6.88	2.312	4.875	1.94	.62	2.995	2.502	2.911	.906	7/8-9	232	7/8-9X3.50
W59-48-48-SS	W60-48-48-SS	3.00	3.00	6.00	8.50	2.812	6.000	2.44	.62	3.615	3.002	3.540	1.190	1-1/8-7	237	1-1/8-7X4.50

CODE 61 FLAT SOCKET WELD - PIPE																
PART NO. O-RING FIG. 1	PART NO. FLAT FACE FIG. 2	PIPE SIZE	PAD SIZE	A	B	C	D	E	F	G	H	J	K	L UNC-2B	MOUNTING HARDWARE	
															O-RING	SHCS
*W72-48-48-SS	*W91-48-48-SS	3.00	3.00	4.50	5.31	2.438	4.188	1.38	1.13	3.615	3.002	3.540	.656	5/8-11	237	5/8-11X2.50
W72-56-56-SS	W91-56-56-SS	3.50	3.50	5.00	6.00	2.750	4.750	1.44	1.19	4.095	3.502	4.054	.656	5/8-11	241	5/8-11X2.50
W72-64-64-SS	W91-64-64-SS	4.00	4.00	5.50	6.38	3.062	5.125	1.450	1.20	4.595	4.002	4.550	.656	5/8-11	245	5/8-11X2.50

\*NOTE: 500 PSI max for W72-48-48-SS & W91-48-48-SS

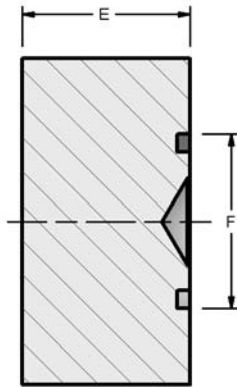
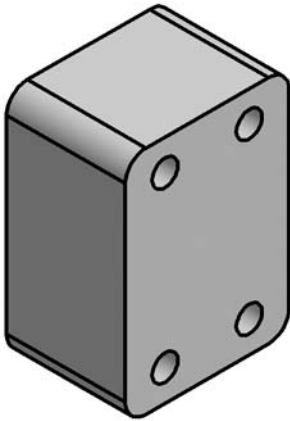

Figure 1

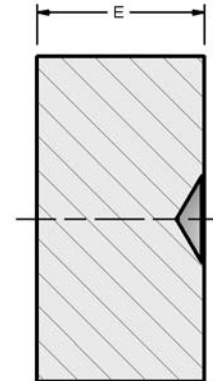
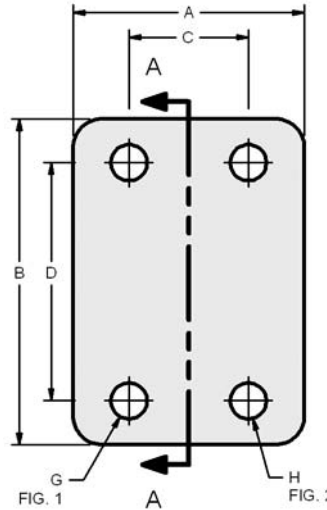

Figure 2

### CODE 61 BLANKING

PART NO. O-RING FIG. 1	PART NO. FLAT FACE FIG. 2	PAD SIZE	A	B	C	D	E	F	G	H UNC-2B	MOUNTING HARDWARE	
											O-RING	SHCS
W36-8-8-SS	W37-8-8-SS	.50	1.50	2.12	.688	1.50	1.20	1.000	.344	5/16-18	210	5/16-18X2.00
W36-12-12-SS	W37-12-12-SS	.75	1.75	2.62	.875	1.875	1.20	1.250	.406	3/8-16	214	3/8-16X2.00
W36-16-16-SS	W37-16-16-SS	1.00	2.00	2.82	1.031	2.063	1.45	1.560	.406	3/8-16	219	3/8-16X2.25
W36-20-20-SS	W37-20-20-SS	1.25	2.50	3.19	1.188	2.313	1.45	1.750	.469	7/16-14	222	7/16-14X2.25
W36-24-24-SS	W37-24-24-SS	1.50	2.75	3.75	1.406	2.750	1.70	2.115	.531	1/2-13	225	1/2-13X2.50
W36-32-32-SS	W37-32-32-SS	2.00	3.25	4.00	1.688	3.063	1.70	2.490	.531	1/2-13	228	1/2-13X2.50
W36-40-40-SS	W37-40-40-SS	2.50	4.00	4.50	2.000	3.500	1.95	2.995	.531	1/2-13	232	1/2-13X2.75
W36-48-48-SS	W37-48-48-SS	3.00	4.50	5.31	2.438	4.188	2.20	3.615	.656	5/8-11	237	5/8-11X3.50
W36-56-56-SS	W37-56-56-SS	3.50	5.00	6.00	2.750	4.750	1.45	4.095	.656	5/8-11	241	5/8-11X2.75
W36-64-64-SS	W37-64-64-SS	4.00	5.50	6.38	3.062	5.125	1.45	4.595	.656	5/8-11	245	5/8-11X2.75

### CODE 62 BLANKING

PART NO. O-RING FIG. 1	PART NO. FLAT FACE FIG. 2	PAD SIZE	A	B	C	D	E	F	G	H UNC-2B	MOUNTING HARDWARE	
											O-RING	SHCS
W38-8-8-SS	W39-8-8-SS	.50	1.75	2.22	.718	1.594	.94	1.000	.344	5/16-18	210	5/16-18X1.50
W38-12-12-SS	W39-12-12-SS	.75	2.00	2.81	.937	2.000	1.19	1.250	.406	3/8-16	214	3/8-16X2.00
W38-16-16-SS	W39-16-16-SS	1.00	2.25	3.19	1.093	2.250	1.44	1.560	.492	7/16-14	219	7/16-14X2.25
W38-20-20-SS	W39-20-20-SS	1.25	2.75	3.75	1.250	2.625	1.44	1.750	.531	1/2-13	222	1/2-13X2.50
W38-24-24-SS	W39-24-24-SS	1.50	3.25	4.50	1.437	3.125	1.69	2.115	.656	5/8-11	225	5/8-11X2.75
W38-32-32-SS	W39-32-32-SS	2.00	4.00	5.25	1.750	3.812	1.69	2.490	.781	3/4-10	228	3/4-10X3.00
W38-40-40-SS	W39-40-40-SS	2.50	5.00	6.88	2.312	4.875	1.94	2.995	.906	7/8-9	232	7/8-9X3.75
W38-48-48-SS	W39-48-48-SS	3.00	6.00	8.50	2.812	6.000	2.44	3.615	1.190	1 1/8-7	237	1 1/8-7X4.50

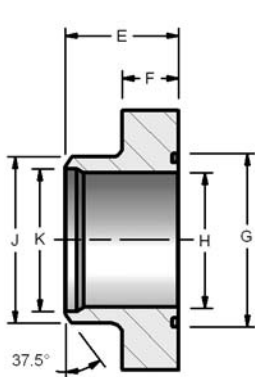

Figure 1

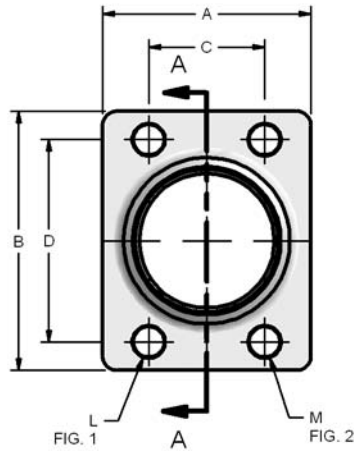

FIG. 1 A M FIG. 2

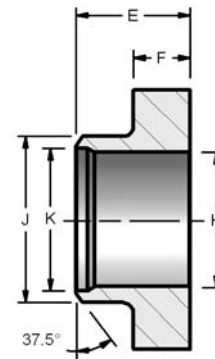
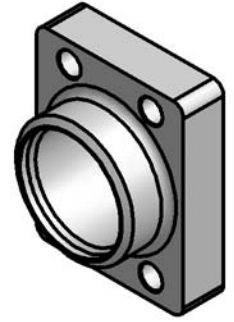

Figure 2



### CODE 61 BUTT WELD - SCHEDULE 40 PIPE

PART NO. O-RING FIG. 1	PART NO. FLAT FACE FIG. 2	PIPE SIZE	PAD SIZE	A	B	C	D	E	F	G	H	J	K	L	M UNC-2B	MOUNTING HARDWARE	
																O-RING	SHCS
W35-8-SS	W34-8-SS	.50	.50	1.47	2.09	.688	1.500	1.06	.50	1.000	.548	.840	.624	.344	5/16-18	210	5/16-18X1.25
W35-12-SS	W34-12-SS	.75	.75	1.69	2.56	.875	1.875	1.06	.50	1.250	.744	1.050	.826	.406	3/8-16	214	3/8-16X1.25
W35-16-SS	W34-16-SS	1.00	1.00	1.94	2.75	1.031	2.062	1.25	.56	1.560	.959	1.315	1.051	.406	3/8-16	219	3/8-16X1.25
W35-20-SS	W34-20-SS	1.25	1.25	2.19	3.12	1.188	2.312	1.44	.62	1.750	1.280	1.660	1.382	.469	7/16-14	222	7/16-14X1.50
W35-24-SS	W34-24-SS	1.50	1.50	2.56	3.69	1.406	2.750	1.75	.81	2.115	1.502	1.900	1.612	.531	1/2-13	225	1/2-13X1.75
W35-32-SS	W34-32-SS	2.00	2.00	3.06	4.00	1.688	3.062	2.00	1.06	2.490	1.941	2.375	2.069	.531	1/2-13	228	1/2-13X2.00
W35-40-SS	W34-40-SS	2.50	2.50	3.56	4.50	2.000	3.500	2.31	1.12	2.995	2.325	2.875	2.471	.531	1/2-13	232	1/2-13X2.00
W35-48-SS	W34-48-SS	3.00	3.00	4.19	5.31	2.438	4.188	2.75	1.62	3.615	2.902	3.500	3.070	.656	5/8-11	237	5/8-11X2.75

### CODE 61 BUTT WELD - SCHEDULE 80 PIPE

PART NO. O-RING FIG. 1	PART NO. FLAT FACE FIG. 2	PIPE SIZE	PAD SIZE	A	B	C	D	E	F	G	H	J	K	L	M UNC-2B	MOUNTING HARDWARE	
																O-RING	SHCS
W24-8-SS	W23-8-SS	.50	.50	1.50	2.12	.688	1.500	1.06	.50	1.000	.546	.840	SCHEDULE 40 ONLY	.344	5/16-18	210	5/16-18X1.25
W24-12-SS	W23-12-SS	.75	.75	1.69	2.56	.875	1.875	1.06	.50	1.250	.752	1.050		.406	3/8-16	214	3/8-16X1.25
W24-16-SS	W23-16-SS	1.00	1.00	1.94	2.75	1.031	2.062	1.25	.56	1.560	.959	1.315		.406	3/8-16	219	3/8-16X1.25
W24-20-SS	W23-20-SS	1.25	1.25	2.19	3.12	1.188	3.312	1.44	.62	1.750	1.280	1.660		.469	7/16-14	222	7/16-14X1.50
W24-24-SS	W23-24-SS	1.50	1.50	2.56	3.69	1.406	2.750	1.75	.81	2.115	1.502	1.900		.531	1/2-13	225	1/2-13X1.75
W24-32-SS	W23-32-SS	2.00	2.00	3.06	4.00	1.688	3.062	2.00	1.06	2.490	1.941	2.375		.531	1/2-13	228	1/2-13X2.00
W24-40-SS	W23-40-SS	2.50	2.50	3.56	4.50	2.000	3.500	2.31	1.12	2.995	2.325	2.875		.531	1/2-13	232	1/2-13X2.00
W24-48-SS	W23-48-SS	3.00	3.00	4.19	5.31	2.438	4.188	2.75	1.62	3.615	2.902	3.500		.656	5/8-11	237	5/8-11X2.75

### CODE 61 BUTT WELD - SCHEDULE 160 PIPE

PART NO. O-RING FIG. 1	PART NO. FLAT FACE FIG. 2	PIPE SIZE	PAD SIZE	A	B	C	D	E	F	G	H	J	K	L	M UNC-2B	MOUNTING HARDWARE	
																O-RING	SHCS
W27-8-SS	W25-8-SS	.50	.50	1.50	2.12	.688	1.500	1.06	.50	1.000	.466	.840	SCHEDULE 40 ONLY	.344	5/16-18	210	5/16-18X1.25
W27-12-SS	W25-12-SS	.75	.75	1.69	2.56	.875	1.875	1.06	.50	1.250	.616	1.050		.406	3/8-16	214	3/8-16X1.25
W27-16-SS	W25-16-SS	1.00	1.00	1.94	2.75	1.031	2.062	1.25	.56	1.560	.817	1.315		.406	3/8-16	219	3/8-16X1.25
W27-20-SS	W25-20-SS	1.25	1.25	2.19	3.12	1.188	2.312	1.44	.62	1.750	1.162	1.660		.469	7/16-14	222	7/16-14X1.50
W27-24-SS	W25-24-SS	1.50	1.50	2.56	3.69	1.406	2.750	1.75	.81	2.115	1.339	1.900		.531	1/2-13	225	1/2-13X1.75
W27-32-SS	W25-32-SS	2.00	2.00	3.06	4.00	1.688	3.062	2.00	1.06	2.490	1.691	2.375		.531	1/2-13	228	1/2-13X2.00
W27-40-SS	W25-40-SS	2.50	2.50	3.56	4.50	2.000	3.500	2.31	1.12	2.995	2.127	2.875		.531	1/2-13	232	1/2-13X2.00
W27-48-SS	W25-48-SS	3.00	3.00	4.19	5.31	2.438	4.188	2.75	1.62	3.615	2.626	3.500		.656	5/8-11	237	5/8-11X2.75

# Butt Weld Pipe

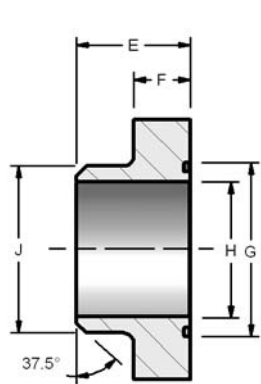
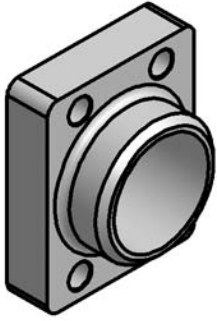

Figure 1

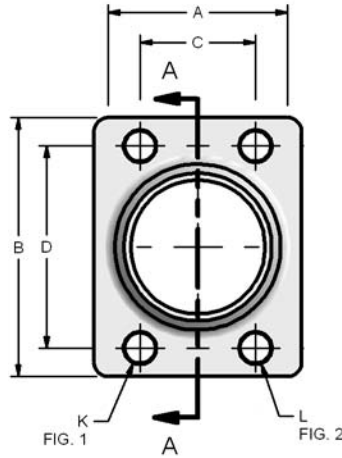

Figure 2

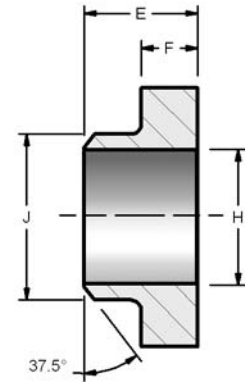

Figure 2

## CODE 62 BUTT WELD - SCHEDULE 80 PIPE

PART NO. O-RING FIG. 1	PART NO. FLAT FACE FIG. 2	PIPE SIZE	PAD SIZE	A	B	C	D	E	F	G	H	J	K	L UNC-2B	MOUNTING HARDWARE	
															O-RING	SHCS
W28-12-SS	W26-12-SS	.75	.75	1.94	2.81	.937	2.000	1.42	.83	1.250	.744	1.050	.406	3/8-16	214	3/8-16X1.50
W28-16-SS	W26-16-SS	1.00	1.00	2.18	3.19	1.093	2.250	1.61	.83	1.560	.959	1.315	.492	7/16-14	219	7/16-14X1.50
W28-20-SS	W26-20-SS	1.25	1.25	2.44	3.75	1.250	2.625	1.73	.94	1.750	1.280	1.660	.531	1/2-13	222	1/2-13X2.00
W28-24-SS	W26-24-SS	1.50	1.50	2.81	4.44	1.437	3.125	2.17	1.10	2.115	1.502	1.900	.656	5/8-11	225	5/8-11X2.25
W28-32-SS	W26-32-SS	2.00	2.00	3.44	5.25	1.750	3.812	2.48	1.46	2.490	1.941	2.375	.781	3/4-10	228	3/4-10X3.00
*W28-40-SS	*W26-40-SS	2.50	2.50	5.00	6.88	2.312	4.875	2.37	1.50	2.995	2.325	2.875	.940	7/8-9	232	7/8-9X3.00
*W28-48-SS	*W26-48-SS	3.00	3.00	6.00	8.50	2.812	6.000	2.96	2.00	3.615	2.902	3.500	1.190	1-1/8-7	237	1-1/8-7X4.00

## CODE 62 BUTT WELD - SCHEDULE 160 PIPE

PART NO. O-RING FIG. 1	PART NO. FLAT FACE FIG. 2	PIPE SIZE	PAD SIZE	A	B	C	D	E	F	G	H	J	K	L UNC-2B	MOUNTING HARDWARE	
															O-RING	SHCS
W30-12-SS	W29-12-SS	.75	.75	1.94	2.81	.937	2.000	1.42	.83	1.250	.616	1.050	.406	3/8-16	214	3/8-16X1.50
W30-16-SS	W29-16-SS	1.00	1.00	2.18	3.19	1.093	2.250	1.61	.83	1.560	.817	1.315	.492	7/16-14	219	7/16-14X1.50
W30-20-SS	W29-20-SS	1.25	1.25	2.44	3.75	1.250	2.625	1.73	.94	1.750	1.162	1.660	.531	1/2-13	222	1/2-13X2.00
W30-24-SS	W29-24-SS	1.50	1.50	2.81	4.44	1.437	3.125	2.17	1.10	2.115	1.339	1.900	.656	5/8-11	225	5/8-11X2.25
W30-32-SS	W29-32-SS	2.00	2.00	3.44	5.25	1.750	3.812	2.48	1.46	2.490	1.691	2.375	.781	3/4-10	228	3/4-10X3.00
*W30-40-SS	*W29-40-SS	2.50	2.50	5.00	6.88	2.312	4.875	2.37	1.50	2.995	2.127	2.875	.940	7/8-9	232	7/8-9X3.00
*W30-48-SS	*W29-48-SS	3.00	3.00	6.00	8.50	2.812	6.000	2.96	2.00	3.615	2.626	3.500	1.190	1-1/8-7	237	1-1/8-7X4.00

## CODE 62 BUTT WELD - SCHEDULE XXS PIPE

PART NO. O-RING FIG. 1	PART NO. FLAT FACE FIG. 2	PIPE SIZE	PAD SIZE	A	B	C	D	E	F	G	H	J	K	L UNC-2B	MOUNTING HARDWARE	
															O-RING	SHCS
W33-12-SS	W32-12-SS	.75	.75	1.94	2.81	.937	2.000	1.42	.83	1.250	.436	1.050	.406	3/8-16	214	3/8-16X1.50
W33-16-SS	W32-16-SS	1.00	1.00	2.18	3.19	1.093	2.250	1.61	.83	1.560	.601	1.315	.492	7/16-14	219	7/16-14X1.50
W33-20-SS	W32-20-SS	1.25	1.25	2.44	3.75	1.250	2.625	1.73	.94	1.750	.898	1.660	.531	1/2-13	222	1/2-13X2.00
W33-24-SS	W32-24-SS	1.50	1.50	2.81	4.44	1.437	3.125	2.17	1.10	2.115	1.102	1.900	.656	5/8-11	225	5/8-11X2.25
W33-32-SS	W32-32-SS	2.00	2.00	3.44	5.25	1.750	3.812	2.48	1.46	2.490	1.505	2.375	.781	3/4-10	228	3/4-10X3.00
*W33-40-SS	*W32-40-SS	2.50	2.50	5.00	6.88	2.312	4.875	2.37	1.50	2.995	1.773	2.875	.940	7/8-9	232	7/8-9X3.00
*W33-48-SS	*W32-48-SS	3.00	3.00	6.00	8.50	2.812	6.000	2.96	2.00	3.615	2.302	3.500	1.190	1-1/8-7	237	1-1/8-7X4.00

\*3000 PSI Max Working Pressure

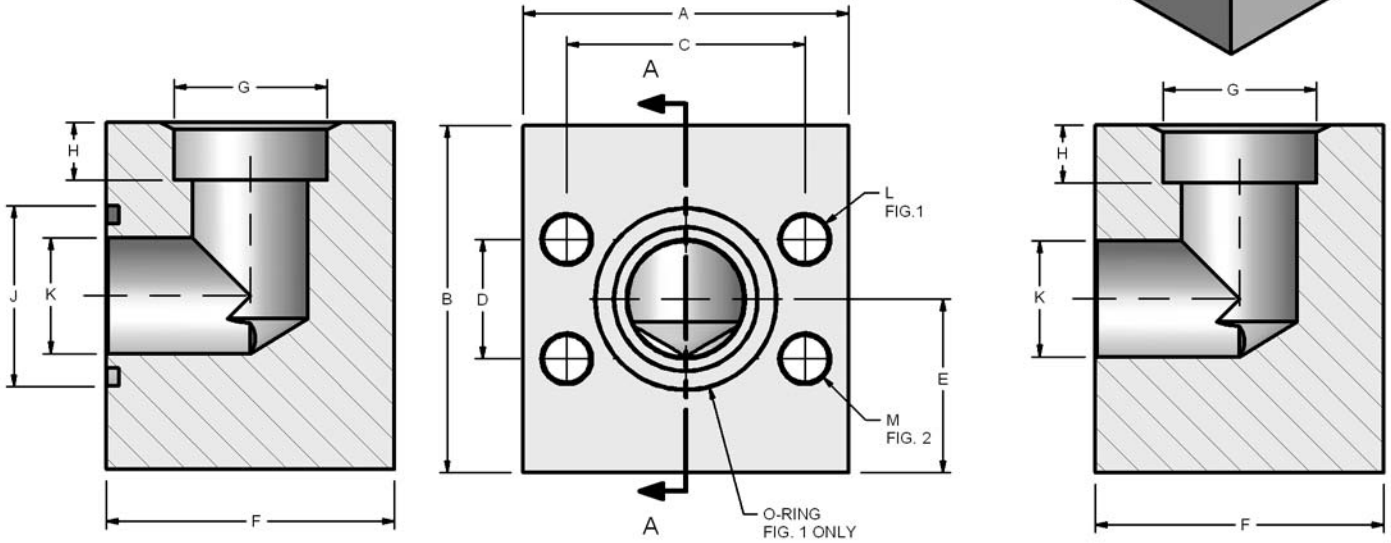

Figure 1

Figure 2

### CODE 61 ELBOW SOCKET WELD - PIPE

PART NO. O-RING FIG. 1	PART NO. FLAT FACE FIG. 2	PIPE SIZE	PAD SIZE	A	B	C	D	E	F	G	H	J	K	L	M UNC-2B	MOUNTING HARDWARE	
																O-RING	SHCS
W176-8-8-SS	W169-8-8-SS	.50	.50	2.12	1.75	1.500	.688	.75	1.44	.855	.380	1.000	.50	.344	5/16-18	210	5/16-18X2.00
W176-12-12-SS	W169-12-12-SS	.75	.75	2.62	2.00	1.875	.875	.88	1.70	1.062	.500	1.250	.75	.406	3/8-16	214	3/8-16X2.50
W176-16-16-SS	W169-16-16-SS	1.00	1.00	2.82	2.25	2.062	1.031	1.00	1.94	1.328	.500	1.560	1.00	.406	3/8-16	219	3/8-16X2.75
W176-20-20-SS	W169-20-20-SS	1.25	1.25	3.19	2.75	2.312	1.188	1.25	2.40	1.672	.500	1.750	1.25	.469	7/16-14	222	7/16-14X3.00
W176-24-24-SS	W169-24-24-SS	1.50	1.50	3.75	3.00	2.750	1.406	1.38	2.90	1.922	.500	2.115	1.50	.531	1/2-13	225	1/2-13X4.00
W176-32-32-SS	W169-32-32-SS	2.00	2.00	4.00	3.50	3.062	1.688	1.62	3.40	2.406	.500	2.490	2.00	.531	1/2-13	228	1/2-13X4.50
W176-40-40-SS	W169-40-40-SS	2.50	2.50	4.50	4.00	3.500	2.000	2.00	3.96	2.906	.500	2.995	2.50	.531	1/2-13	232	1/2-13X5.00
W176-48-48-SS	W169-48-48-SS	3.00	3.00	5.31	5.00	4.188	2.438	2.25	4.96	3.547	.625	3.615	3.00	.656	5/8-11	237	5/8-11X6.00

### CODE 62 ELBOW SOCKET WELD - PIPE

PART NO. O-RING FIG. 1	PART NO. FLAT FACE FIG. 2	PIPE SIZE	PAD SIZE	A	B	C	D	E	F	G	H	J	K	L	M UNC-2B	MOUNTING HARDWARE	
																O-RING	SHCS
W186-8-8-SS	W189-8-8-SS	.50	.50	2.22	2.00	1.594	.718	.88	1.46	.860	.380	1.000	.50	.344	5/16-18	210	5/16-18X2.25
W186-12-12-SS	W189-12-12-SS	.75	.75	2.81	2.25	2.000	.937	1.00	1.70	1.062	.500	1.250	.75	.406	3/8-16	214	3/8-16X2.50
W186-16-16-SS	W189-16-16-SS	1.00	1.00	3.19	2.50	2.250	1.093	1.12	2.21	1.328	.500	1.560	1.00	.492	7/16-14	219	7/16-14X3.25
W186-20-20-SS	W189-20-20-SS	1.25	1.25	3.75	3.00	2.625	1.250	1.38	2.44	1.672	.500	1.750	1.25	.531	1/2-13	222	1/2-13X3.25
W186-24-24-SS	W189-24-24-SS	1.50	1.50	4.50	3.50	3.125	1.437	1.62	2.96	1.922	.500	2.115	1.50	.656	5/8-11	225	5/8-11X4.25
W186-32-32-SS	W189-32-32-SS	2.00	2.00	5.25	4.00	3.812	1.750	2.00	3.46	2.406	.500	2.490	2.00	.781	3/4-10	228	3/4-10X5.00



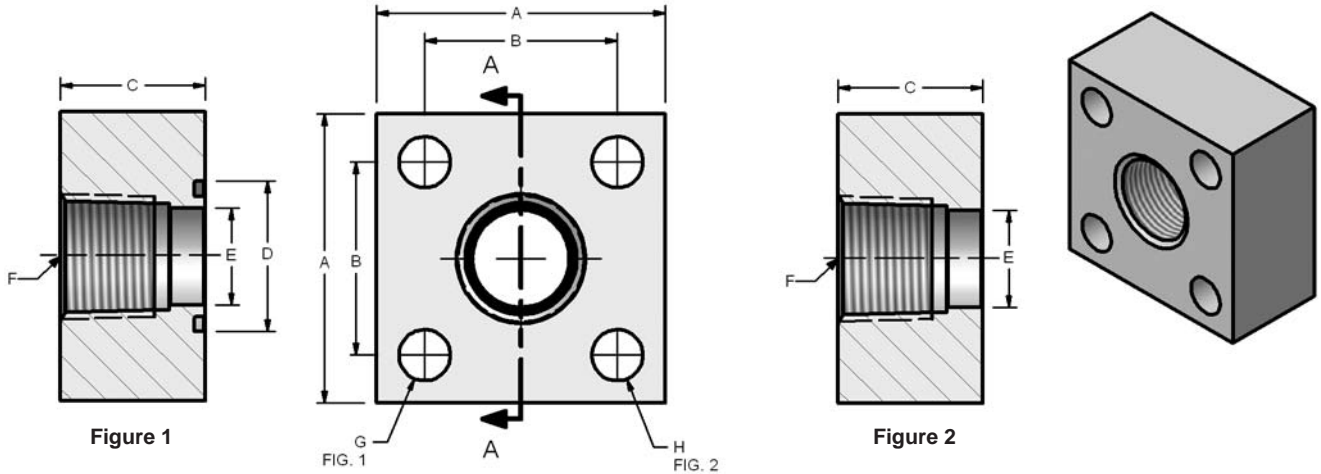

Figure 1

FIG. 1 A H FIG. 2

Figure 2

3000 SERIES SQUARE NPTF THREAD												
PART NO. O-RING FIG. 1	PART NO. FLAT FACE FIG. 2	PIPE SIZE	A	B	C	D	E	F NPTF	G	H UNC-2B	MOUNTING HARDWARE	
											O-RING	SHCS
W65-12-SS	W75-12-SS	.75	2.25	1.438	1.25	1.250	.752	.75	.406	3/8-16	214	3/8-16X2.00
W65-16-SS	W75-16-SS	1.00	3.00	2.000	1.50	1.560	1.002	1.00	.531	1/2-13	219	1/2-13X2.25
W65-20-SS	W75-20-SS	1.25	3.00	2.000	1.50	1.750	1.252	1.25	.531	1/2-13	222	1/2-13X2.25
W65-24-SS	W75-24-SS	1.50	4.00	2.750	1.75	2.115	1.502	1.50	.656	5/8-11	225	5/8-11X2.75
W65-32-SS	W75-32-SS	2.00	4.00	2.750	1.75	2.490	2.002	2.00	.656	5/8-11	228	5/8-11X2.75
W65-40-SS	W75-40-SS	2.50	5.50	3.750	2.25	2.995	2.502	2.50	.906	7/8-9	232	7/8-9X3.50
W65-48-SS	W75-48-SS	3.00	5.50	3.750	2.25	3.615	3.002	3.00	.906	7/8-9	237	7/8-9X3.50

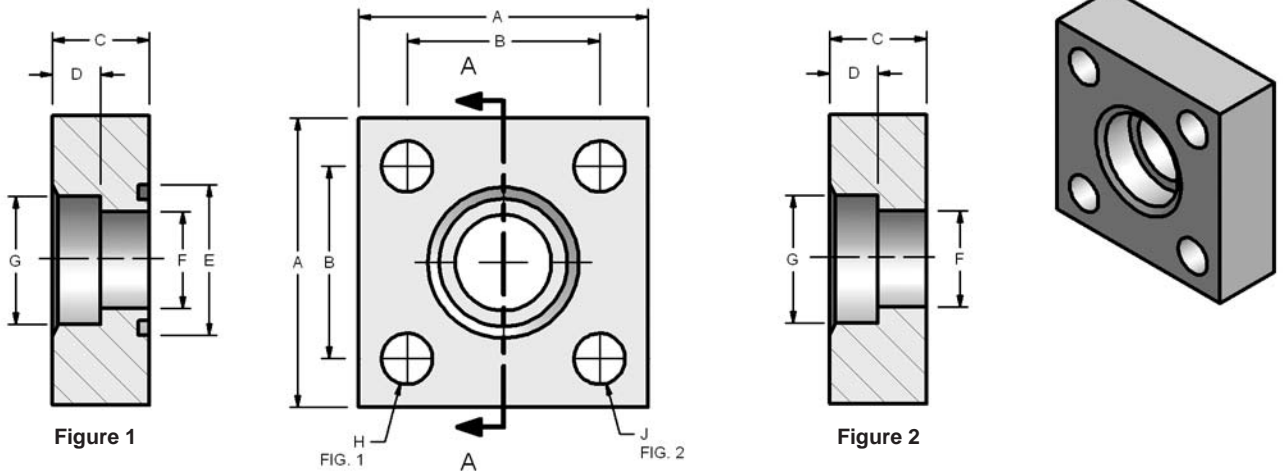

Figure 1

FIG. 1 H J FIG. 2

Figure 2

3000 SERIES SQUARE SOCKET WELD - PIPE													
PART NO. O-RING FIG. 1	PART NO. FLAT FACE FIG. 2	PIPE SIZE	A	B	C	D	E	F	G	H	J UNC-2B	MOUNTING HARDWARE	
												O-RING	SHCS
W66-12-SS	W76-12-SS	.75	2.25	1.438	1.00	.50	1.250	.752	1.062	.406	3/8-16	214	3/8-16X1.75
W66-16-SS	W76-16-SS	1.00	3.00	2.000	1.00	.50	1.560	1.002	1.328	.531	1/2-13	219	1/2-13X1.75
W66-20-SS	W76-20-SS	1.25	3.00	2.000	1.00	.50	1.750	1.252	1.672	.531	1/2-13	222	1/2-13X1.75
W66-24-SS	W76-24-SS	1.50	4.00	2.750	1.25	.62	2.115	1.502	1.922	.656	5/8-11	225	5/8-11X2.25
W66-32-SS	W76-32-SS	2.00	4.00	2.750	1.25	.62	2.490	2.002	2.406	.656	5/8-11	228	5/8-11X2.25
W66-40-SS	W76-40-SS	2.50	5.50	3.750	1.50	.75	2.995	2.502	2.906	.906	7/8-9	232	7/8-9X2.75
W66-48-SS	W76-48-SS	3.00	5.50	3.750	1.50	.75	3.615	3.002	3.547	.906	7/8-9	237	7/8-9X2.75

All measurements are in inches.

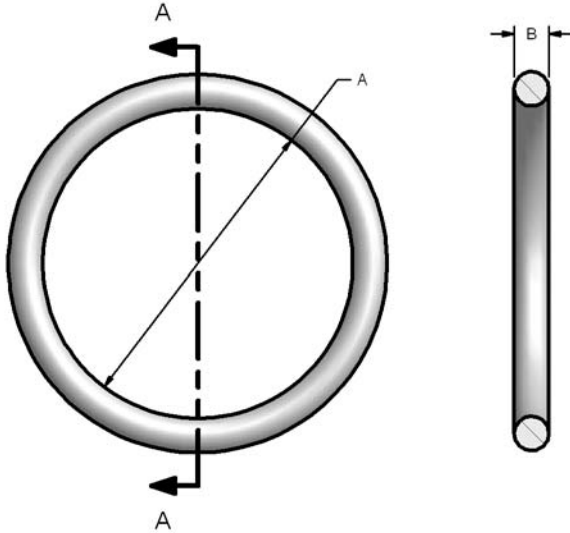

90 DUROMETER BUNA-N O-RING FOR SPLIT CLAMP HEADS			
O-RING	SIZE	A	B
210	0.50	0.75	0.139
214	0.75	1.00	0.139
219	1.00	1.31	0.139
222	1.25	1.50	0.139
225	1.50	1.88	0.139
228	2.00	2.25	0.139
232	2.50	2.75	0.139
237	3.00	3.38	0.139
241	3.50	3.88	0.139
245	4.00	4.38	0.139
253	5.00	5.38	0.139

ALSO AVAILABLE IN VITON

### STANDARD "ANCHOR FLUID POWER" O-RING GROOVE

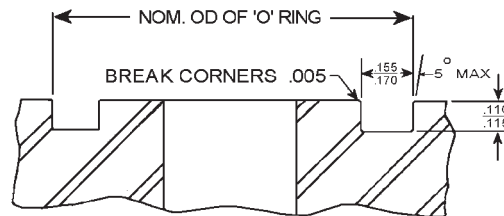

#### LIMITED WARRANTY

Anchor Fluid Power warrants only that the products conform to the dimensions set forth in its catalog at the time of sale. Catalog dimensions are subject to change. This warranty is made in lieu of all other warranties, expressed or implied. All other warranties, expressed or implied, **INCLUDING ANY WARRANTY OF MERCHANTABILITY OR FITNESS FOR A PARTICULAR PURPOSE**, are excluded and will not apply to the products sold.

Buyer must obtain written authorization from Anchor Fluid Power prior to returning products. Nonconforming products must be returned to Anchor Fluid Power within 30 days of delivery to buyer.

Internal material defects may not be commercially detectable. Under no circumstances will Anchor Fluid Power be liable for any damages or claims with respect to soundness of material.

No employee, agent, or representative of Anchor Fluid Power has the authority to vary the terms of the warranty described herein, or to extend this warranty to anyone other than Anchor Fluid Power's direct customers.

#### LIMITATION OF DAMAGES

Buyer's sole and exclusive remedy against Anchor Fluid Power for nonconforming products will be the furnishing of replacement products (F.O.B. Anchor Fluid Power) or refund credit.

Anchor Fluid Power shall not be liable to buyer, its employees, agents, customers, or to any third party for any claim, loss or damage, general or specific, incidental or consequential, including but not limited to death, personal injury, property damage, lost sales or lost profit, which in any way arises out of or in connection with the sale of any product or the use or nonuse of such products, even if Anchor Fluid Power has been advised of the possibility of such loss or damage.